

# HDMI over IP Extender with USB KVM Function (150M)



**User Manual**

**VER 1.0**

# Thank you for purchasing this product

For optimum performance and safety, please read these instructions carefully before connecting, operating or adjusting this product. Please keep this manual for future reference.

## Surge protection device recommended

This product contains sensitive electrical components that may be damaged by electrical spikes, surges, electric shock, lightning strikes, etc. Use of surge protection systems is highly recommended in order to protect and extend the life of your equipment.

## Table of Contents

1. Introduction.....	1
2. Features.....	1
3. Package Contents.....	1
4. Specifications.....	2
5. Operation Controls and Functions.....	3
5.1 Encoder Panel.....	3
5.2 Decoder Panel.....	4
5.3 IR Pin Definition.....	4
6. Application Example.....	5

## 1. Introduction

HDMI over IP Extender adopts standard H.265 encoding / decoding. It can distribute one HD content to one HD display device or to multiple HD display devices over a standard 1G network switcher, and extends distance up to 150m/492ft between encoder and decoder via a Cat5e/6 cable. It offers configurable high quality, low-bandwidth H.265 compression video. Input video resolution is up to 1920×1200@60Hz; Output video resolution is up to 1080P@60Hz. It also supports USB KVM function and one-way IR control signal transmission.

HDMI over IP Extender includes two units: Encoder and Decoder. Encoder is responsible for obtaining HDMI signals for encoding, and transmitting via CAT5e / 6 cables. Decoder is responsible for signal decoding and outputting HDMI signals to HD displays. The product offers the most convenient solution for HDMI extension over a single Cat5e/6 cable and is the perfect solution for any application.

## 2. Features

- ☆ HDCP 1.4 compliant
- ☆ Support 6.75Gbps video bandwidth
- ☆ Input video resolution is up to 1920×1200@60Hz YCbCr 4:4:4; Output video resolution is up to 1080P@60Hz YCbCr 4:4:4
- ☆ Extend transmission distance up to 150m/492ft between encoder and decoder via a single Cat5e/6 cable
- ☆ Adopt standard H.265 encoding / decoding
- ☆ Support 1G standard IP switcher / router / hub
- ☆ Support one-way IR control signal transmission
- ☆ With USB KVM function
- ☆ Compact design for easy and flexible installation

## 3. Package Contents

- ① 1× HDMI over IP Extender (Encoder)
- ② 1× HDMI over IP Extender (Decoder)
- ③ 1× IR Blaster cable (1.5 meters)
- ④ 1× 20~60KHz IR Receiver cable (1.5 meters)
- ⑤ 2× 5V/1A Power Supply (US standard)
- ⑥ 1× User Manual

## 4. Specifications

Technical	
HDCP Compliance	HDCP 1.4
USB Version	USB 1.1
Video Bandwidth	6.75Gbps
Video Resolution	Input: Up to 1920×1200@60Hz Output: Up to 1080P@60Hz
HDMI Audio Formats	Input: LPCM 2.0CH 32KHz/44.1KHz/48KHz Output: LPCM 2.0CH 48KHz
IR Frequency	20Hz ~ 60KHz
Compression Technology	H.265
Request for Switcher /Router	Support 1 GMP, Support DHCP
Color Space	RGB, YCbCr 4:4:4, YCbCr 4:2:2
Color Depth	8/10/12-bit
ESD Protection	Human body model—±8kV (Air-gap discharge) & ±4kV (Contact discharge)
Connection	
Encoder	Inputs: 1×HDMI IN [Type A, 19-pin female] Outputs: 1×LAN [RJ45 connector] Control: 1×IR OUT [3.5mm Stereo Mini-jack] 1×USB [USB-B, female]
Decoder	Inputs: 1×LAN [RJ45 connector] Outputs: 1×HDMI OUT [Type A, 19-pin female] Control: 1×IR IN [3.5mm Stereo Mini-jack] 2×USB [USB-A, female]
Mechanical	
Housing	Metal Enclosure
Silkscreen Color	Black
Dimensions	67mm (W) × 91.5mm (D) × 17.5mm (H)
Weight	Encoder: 155g, Decoder: 150g
Power Supply	Input: AC100 - 240V 50/60Hz Output: DC 5V/1A
Power Consumption	Encoder: 2.9W, Decoder: 3.65W (Max)

Operation Temperature	-10°C ~ 50°C / 14°F ~ 122°F
Storage Temperature	-20°C ~ 60°C / -4°F ~ 140°F
Relative Humidity	20~90% RH (non-condensing)
<b>Resolution / Distance</b>	<b>1920x1200@60Hz - Feet / Meter</b>
CAT 5e/6 cable	492ft / 150 meters
<b>Resolution / Cable length</b>	<b>1920x1200@60Hz - Feet / Meter</b>
HDMI IN / OUT	50ft / 15 meters

## 5. Operation Controls and Functions

### 5.1 Encoder Panel

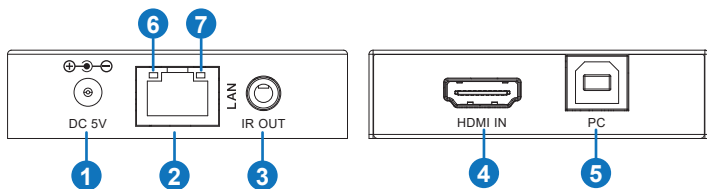

No.	Name	Function Description
1	DC 5V	5V 1A input port for power supply.
2	LAN	The LAN port is connected to decoder's LAN port or connected to switcher / router / hub with CAT cable.
3	IR OUT	Connect to IR blaster cable. The IR blaster signal is from IR IN of decoder.
4	HDMI IN	HDMI source input port for connecting the HDMI source device.
5	PC	Connect to PC. The PC can be controlled for USB port of decoder. (KVM function)
6	Data signal indicator (orange)	The lamp flickers when the LAN port is transmitting signal.
7	Power LED indicator (green)	The lamp is on when encoder is powered on.

## 5.2 Decoder Panel

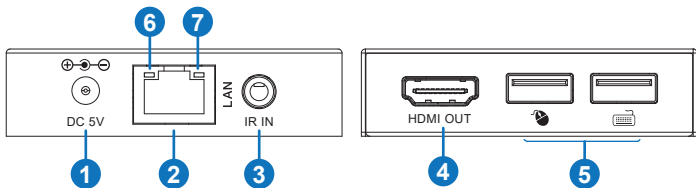

No.	Name	Function Description
1	DC 5V	5V 1A input for power supply.
2	LAN	The LAN port is connected to encoder's LAN port or connected to switcher / router / hub with CAT cable.
3	IR IN	Connect to IR receiver cable. The IR signal is sent to IR OUT port of encoder.
4	HDMI OUT	HDMI output port for connecting the HDMI display device.
5	Two USB port	USB 1.1 for connecting mouse and USB keyboard.
6	Data signal indicator (orange)	The lamp flickers when the LAN port is transmitting signal.
7	Power LED indicator (green)	The lamp is on when decoder is powered on.

## 5.3 IR Pin Definition

IR Receiver and Blaster pin's definition as below:

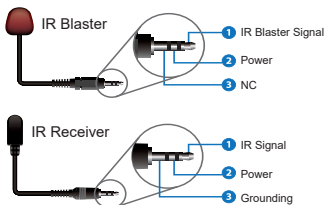

## 6. Application Example

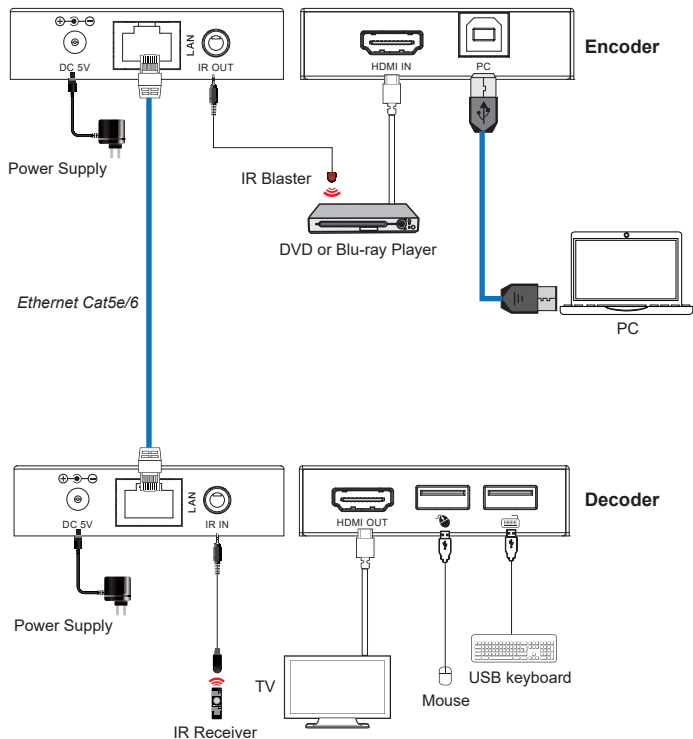

Figure 1: Encoder directly connects to Decoder

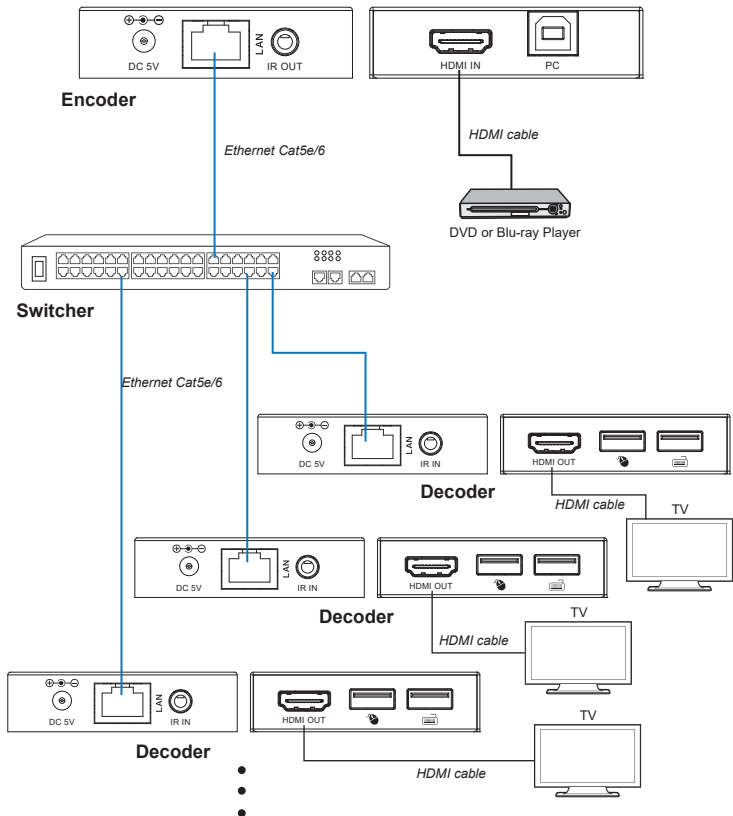

Figure 2: Encoder connects to Decoder via a switcher  
(one Encoder to multiple Decoders)