



AEON SERIES

Section 1: Screen Design

1.1 What is it for?

The **Aeon Series** is a fixed frame projection screen that uses Elite’s EDGE FREE® technology. The EDGE FREE® design resembles a giant size flat panel TV display. The **Aeon** includes an ultra-thin trim as an installation option to further enhance the overall appearance.

1.2 How does it work?

The screen material is stretched over an aluminum lightweight split-frame for a permanently tight-tensioned flat surface. Easy to assemble and install in minutes with your choice of an EDGE FREE® or install ultra-thin trim.

Section 2: Product Features

2.1 Characteristics

Screen Material

- Stretches over frame for a permanently tight-tensioned flat surface
- Active 3D, 4K Ultra HD, and HDR Ready
- Available in the following diagonal sizes: 84" - 200" in 16:9 format, 103" - 158" in 2.35:1 format

Design and Installation

- Aluminum lightweight split-frame design
- Easy to assemble and install in minutes
- EDGE FREE® or install ultra-thin trim
- Smaller footprint maximizes viewing area
- Wall mount brackets slide ensuring the frame is properly centered
- Optional LED backlight kit with remote control

Quality and Reliability

- 2-year Parts & Labor manufacturer's warranty
- 3-year warranty offered through ENR-G program (Education, Non-Profit, Religious and Government)

2.2 Model Numbers

Model Number	Diag. Size	Aspect Ratio	Viewing Height (in)	Viewing Width (in)	Screen Material	Gain	Case Color	N.W. (lbs)	G.W. (lbs)	Packaging (LxWxH)
AR92WH2	92"	16:9	45.1	80.2	CineWhite™	1.1	N/A	19.3	28.0	55.5"x6.7"x11.8"
AR100WH2	100"	16:9	49.2	87.3	CineWhite™	1.1	N/A	21.3	30.8	59.3"x6.7"x11.8"
AR110WH2	110"	16:9	53.9	95.9	CineWhite™	1.1	N/A	21.9	30.4	64.2"x6.7"x13.6"
AR120WH2	120"	16:9	58.3	104.1	CineWhite™	1.1	N/A	25.2	35.2	68.3"x6.7"x11.8"

PRODUCT WHITE PAPER

<http://www.elitescreens.com>



AR135WH2	135"	16:9	66.3	117.9	CineWhite™	1.1	N/A	27.5	36.9	76"x6.5"x11.8"
AR150WH2	150"	16:9	71.5	130.9	CineWhite™	1.1	N/A	31.8	43.6	83.7"x5.6"x15.5"
AR180WH2	180"	16:9	88.2	156.9	CineWhite™	1.1	N/A	40.9	53.5	97.8"x6.7"x15.8"
AR200WH2	200"	16:9	98.0	174.4	CineWhite™	1.1	N/A	45.0	59.3	107.7"x6.7"x15.8"
AR100H2	100"	16:9	49.2	87.3	CineGrey	1.0	N/A	20.8	30.9	59.3"x6.7"x11.8"
AR120H2	120"	16:9	58.3	104.1	CineGrey	1.0	N/A	25.2	34.4	68.3"x6.7"x12.8"
AR135H2	135"	16:9	66.3	117.9	CineGrey	1.0	N/A	29.5	40.3	75.8"x6.7"x13.4"
AR92DHD3	92"	16:9	45.1	80.2	CineGrey 3D®	1.2	N/A	18.3	27.8	55.5"x6.7"x11.8"
AR100DHD3	100"	16:9	49.2	87.3	CineGrey 3D®	1.2	N/A	19.8	29.5	59.3"x6.7"x11.8"
AR110DHD3	110"	16:9	49.2	87.3	CineGrey 3D®	1.2	N/A	22.1	30.5	64.17"x6.7"x13.6"
AR120DHD3	120"	16:9	58.3	104.1	CineGrey 3D®	1.2	N/A	23.6	32.7	68.3"x6.7"x13.7"
AR135DHD3	135"	16:9	66.3	117.9	CineGrey 3D®	1.2	N/A	28.1	38.6	75.8"x6.7"x15.2"
AR150DHD3	150"	16:9	71.5	130.9	CineGrey 3D®	1.2	N/A	31.3	42.8	83.3"x6.7"x15.2"
AR103WH2-WIDE	103"	2.35:1	40.3	94.8	CineWhite™	1.1	N/A	19.8	27.9	56.7"x6.7"x13.4"
AR125WH2-WIDE	125"	2.35:1	49.0	115.0	CineWhite™	1.1	N/A	23.1	34.4	66.9"x6.7"x15"
AR138WH2-WIDE	138"	2.35:1	53.9	127.0	CineWhite™	1.1	N/A	26.9	37.6	72.8"x6.7"x15.2"
AR158WH2-WIDE	158"	2.35:1	61.9	145.4	CineWhite™	1.1	N/A	30.4	43.5	82.1"x6.7"x15.8"
AR100H2-AUHD	100"	16:9	49.0	87.2	AcousticPro UHD	1.0	N/A	23.1	29.7	59.1"x11.8"x6.7"
AR120H2-AUHD	120"	16:9	58.2	103.9	AcousticPro UHD	1.0	N/A	29.5	38.1	68.3"x13.4"x6.5"
AR100DHD3	100"	16:9	49.0	87.2	CineGrey 3D®	1.2	N/A	22.1	30.5	64.17"x6.7"x13.6"
AR110DHD3	110"	16:9	53.9	95.9	CineGrey 3D®	1.2	N/A	23.6	32.7	68.3"x6.7"x13.7"
AR120DHD3	120"	16:9	58.8	104.6	CineGrey 3D®	1.2	N/A	28.1	38.6	75.8"x6.7"x15.2"
AR135DHD3	135"	16:9	66.2	117.6	CineGrey 3D®	1.2	N/A	31.3	42.8	83.3"x6.7"x15.2"
AR150DHD3	150"	16:9	73.5	130.7	CineGrey 3D®	1.2	N/A	19.8	29.5	56.7"x6.7"x13.4"

Section 3: Screen Material Specifications

3.1 Characteristics

3.1.1 CineWhite™

CineWhite™ (Tension Matte White) has broad light dispersion through diffusion uniformity, black & white contrast and true color rendition making it the most versatile in Elite's tensions screen product lines. This tension PVC surface is the best choice for today's

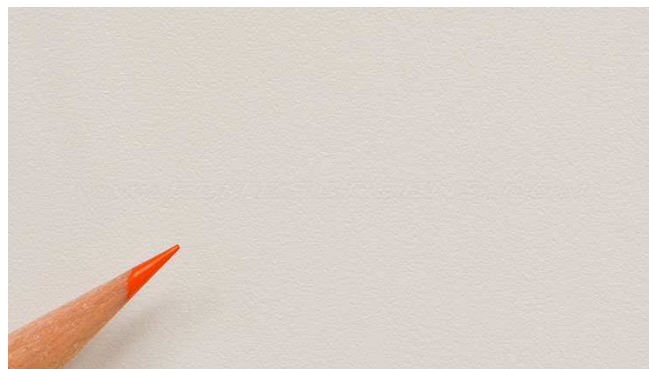

high-contrast ratio projectors in commercial or residential presentations. The **CineWhite™** material

PRODUCT WHITE PAPER

<http://www.elitescreens.com>



equals the performance to our MaxWhite™ product, but improves the experience with the superior surface flatness. Uniform diffusion surface has black-backing to eliminate light penetration and is easily washable with mild soap and water.

Features & Benefits

- Multi-layer PVC (Polyvinyl chloride) with texture and surface coating
- Gain: 1.1
- View Angle: 180° (90° ±LR)
- Full Lambertian Diffuser- no half gain drop
- Produces exceptional picture quality for any presentation
- Mildew Resistant
- Active 3D and 4K Ultra HD ready
- Surface can be cleaned with (water) moist cotton cloth

Specifications	
Thickness	0.27 mm
Weight	350 g/m2
Maximum Height	3.2 M (10 ft)
On-axis Gain	1.1
Half-Gain Angle	Does not reach half gain

3.1.2 CineGrey 3D®

The **CineGrey 3D®** is a reference quality front projection screen material formulated for environments with minimal control over room lighting. It was designed to enhance picture brightness, offer accurate color fidelity, and improve contrast levels. The **CineGrey 3D®** is best for family rooms, educational facilities, conference rooms or any applications in which



incident light is a factor. Typical matte white surfaces wash out the images when ambient light cannot be controlled. The **CineGrey 3D®** is the best choice for having a projected image with a balanced color temperature and contrast under such conditions. It provides flat spectral response for an accurate color balance in dark room environments as well for reference quality applications. The **CineGrey 3D®** is ready for the next-generation of high-performance video.

Features & Benefits

- Gain: 1.2

- Viewing Angle: 90° (45° L/R)
- Angular-Reflective front projection material with ambient light rejecting technology
- Contrast enhancement over standard matte white surface
- 4K Ultra HD and Active 3D Ready
- Polarized for Passive 3D applications
- Capable of improving brightness, color, and contrast under ambient light conditions
- Mildew resistant, screen surface can be cleaned with a microfiber cloth and water
- Accurate color representation – Flat Spectral Response
- Certified by the **Imaging Science Foundation** (ISF)

Specifications	
Thickness	0.30 mm
Weight	300 g/m ²
Maximum Height	3.0 M (9.8 ft)
On-axis Gain	1.2
Half-Gain Angle	At 44°

3.1.3 CineGrey

CineGrey (Tension High Contrast Grey) is designed for low contrast DLP and LCD Home Cinema Projectors. Its superior flatness makes the CineGrey ideal for home theater use. It enhances black levels while minimizing loss in color reproduction. Uniform diffusion surface has black-backing to eliminate light penetration and is easily washable with mild soap and water. *Manufacturer's Tip: if your projector's contrast ratio is more than 2000:1, we recommend you use CineWhite™ material for a brighter picture.

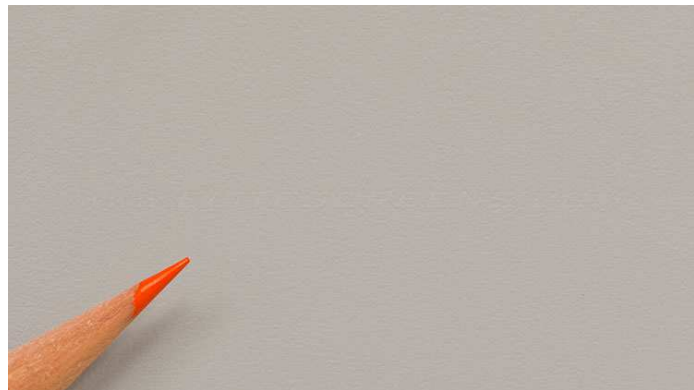

*Manufacturer's Tip: if your projector's contrast ratio is more than 2000:1, we recommend you use CineWhite™ material for a brighter picture.

Features & Benefits

- Multi-layer PVC with texture and surface coating
- Gain: 1.0
- View Angle: 160° (80° ±LR)
- Mildew Resistant
- Black backing
- Surface can be cleaned with (water) moist cotton cloth
- Active 3D and 4K Ultra HD ready

Specifications	
Thickness	0.3 mm
Weight	350 g/m2
Maximum Height	3.2 M (10 ft)
On-axis Gain	1.0
Half-Gain Angle	At 50°

3.1.4 AcousticPro UHD

The **AcousticPro UHD (ultra-high definition)** is a moiré-free self-supported acoustically transparent front projection screen material. The dense synthetic weave is compatible with Ultra-High Definition/4K resolutions while mitigating light penetration for a brighter picture. The **AcousticPro UHD** design maximizes sound penetration with



minimal attenuation without compromising picture quality. The **AcousticPro UHD** material’s wide diffusion uniformity offers a broad viewing angle with superb picture quality across the entire surface. This provides equal brightness levels on or off axis.

Features & Benefits

- Gain: 1.0
- Viewing Angle: 180° (90°L/R)
- Moiré-free
- Wide diffusion uniformity – maintains luminance levels throughout entire surface
- Mildew Resistant
- 4K UHD and Active 3D ready
- Mean Attenuation: -2.36dB
- Flame Retardant: Complies with NFPA 701 Standards

Specifications	
Thickness	0.40 mm
Weight	500 g/m2
Maximum Height	2.5 M (8.2 ft)
On-axis Gain	1.0
Half-Gain Angle	Does not reach half gain

3.2 Gain Chart

3.2.1 CineWhite™



On axis 0° Gain: 1.1
Viewing Cone: 180°

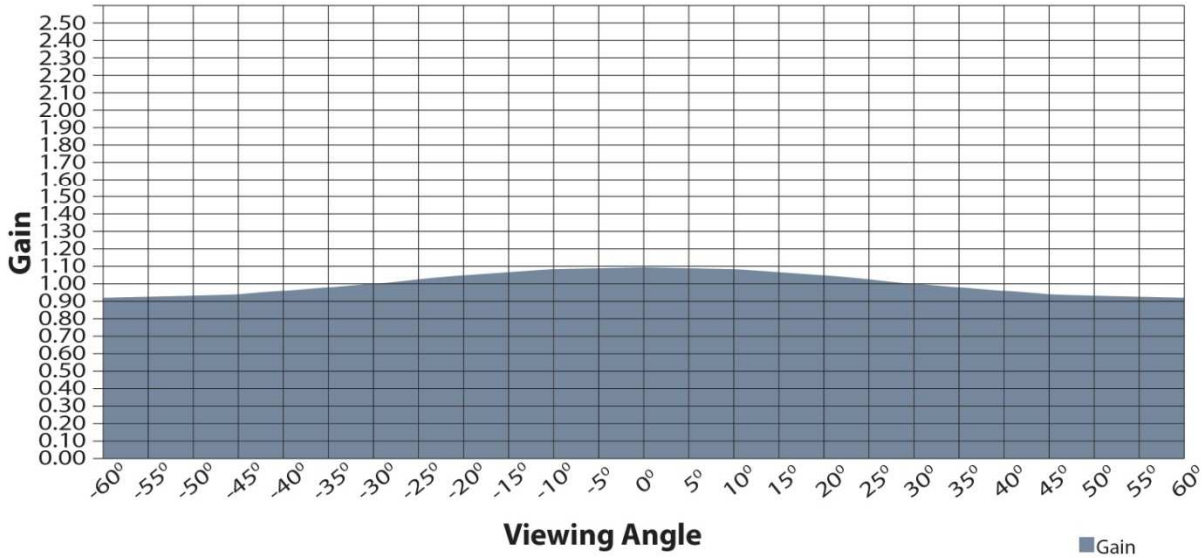

3.2.2 CineGrey 3D®



On axis 0° Gain: 1.2
Viewing Cone: 45°

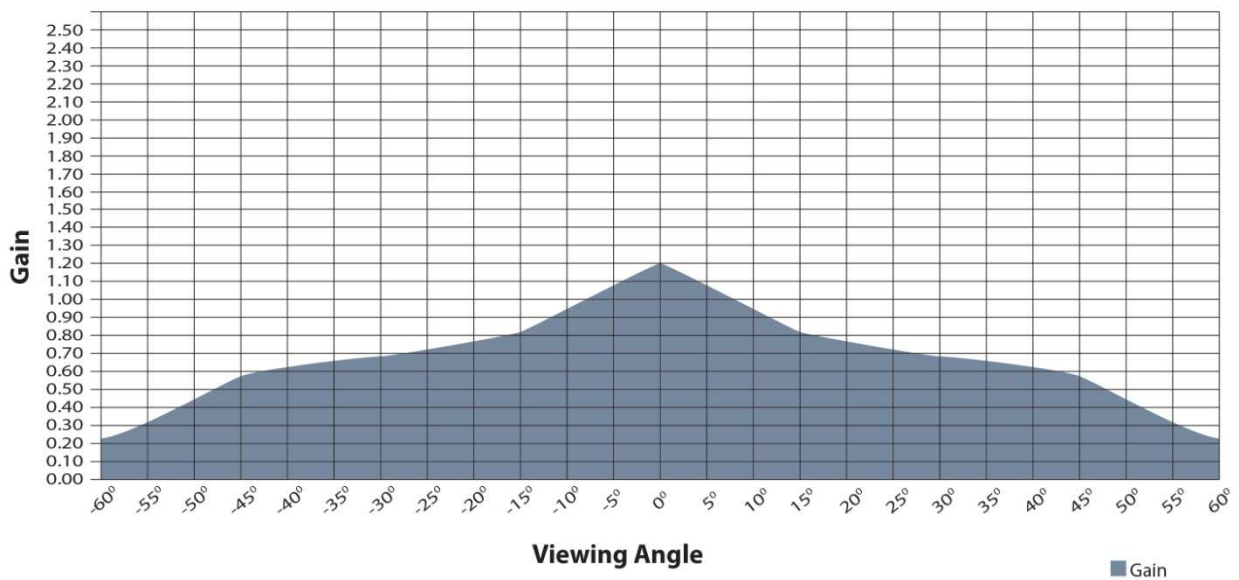

3.2.3 CineGrey



On axis 0° Gain: 1.0
Viewing Cone: 160°

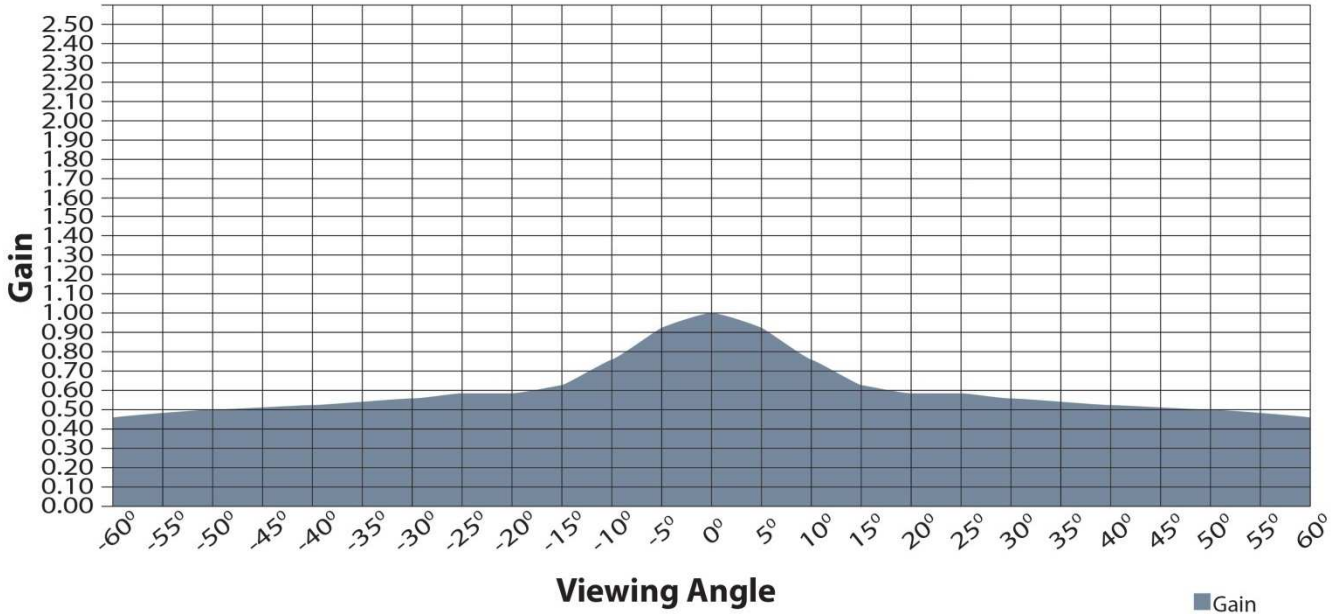

3.2.4 AcousticPro UHD



On axis 0° Gain: .80
Viewing Cone: 180°

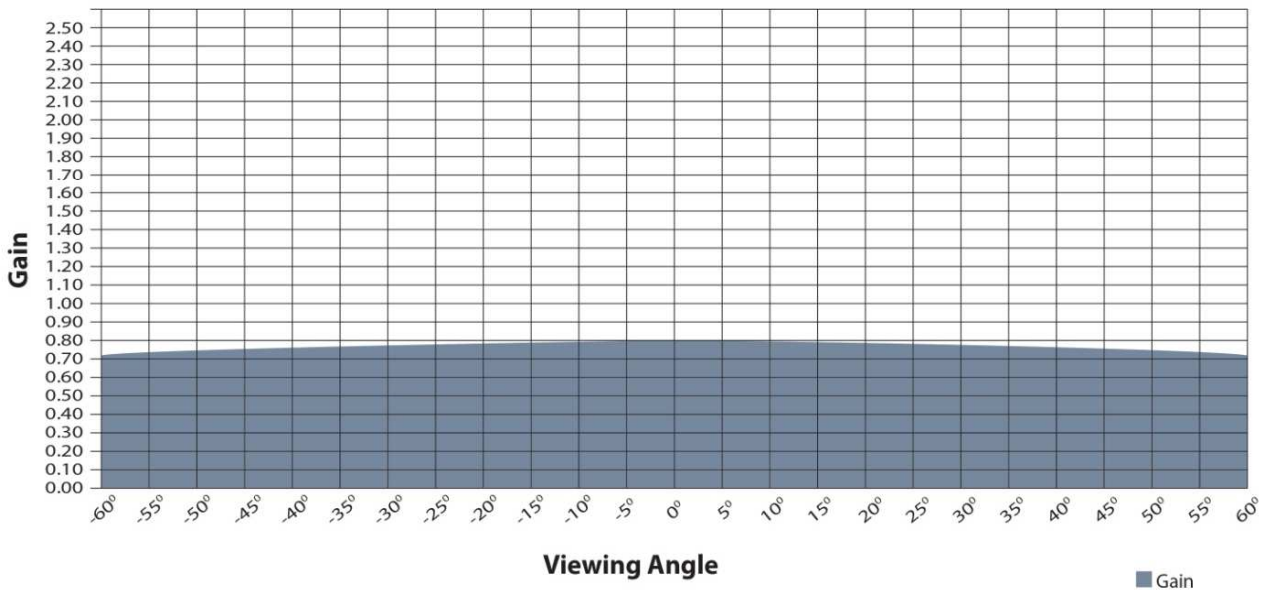







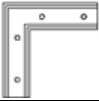
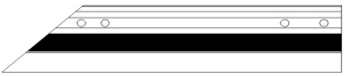

Section 4: Execution

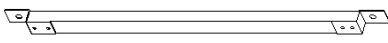
4.1 Velcro Type

4.1.1 Hardware and Parts List

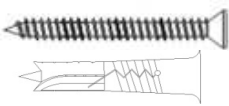
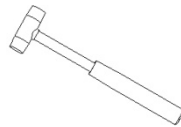
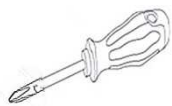
Please make sure all parts listed below are included before installation.

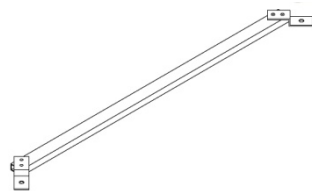
<p>A. Elbow joint x 4 pcs</p> 	<p>B. Top/Bottom horizontal frame x 4 pcs</p> 	<p>C. Left/Right vertical frame x 2 pcs</p> 
<p>D. Center joints x 2 pcs</p> 	<p>E. Center Support bar x 1-2 pc</p> 	<p>F. Wall brackets x 2-3 pcs</p> 
<p>G. M6 screw x 2-12 pcs</p> 	<p>H. M5x15 screw x 24 pcs</p> 	<p>I. M6x12 screw x 2-12pcs</p> 
<p>J. M5x50 screws/anchor x 6 pcs</p> 	<p>K. Rubber hammer x 1 pc</p> 	<p>L. Screwdriver x1 pc</p> 
<p>M. Velvet tape</p>	<p>N. Corner Support Bar (180"-200") x 4 pcs</p>	
		

4.1.2 Frame Assembly

1. Insert the *center joint* (D) into one of the ½ *horizontal frames* (B) and fasten it with the two *M5x15 screws* (H).
2. Insert the other ½ horizontal frame piece to the center joint and fasten also using two *M5x15 screws*.
3. Repeat steps 1 and 2 for assembling the second horizontal frame.

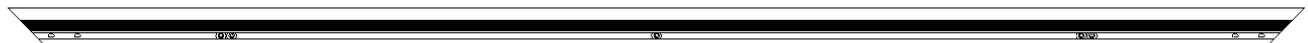
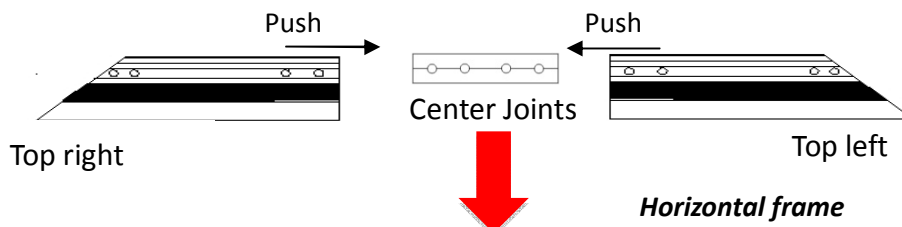

4. For models 150" and below, insert and slide in one **M6 screw (G)** through the channel located on the back each **horizontal frame section** (top/bottom).

Note: For models 180" and above, insert and slide in four **M6 screws** (two on each frame) through the channel located on the back of each **horizontal frame section** (top/bottom). Insert two **M6 screws** on each **vertical frame section** (left/right).

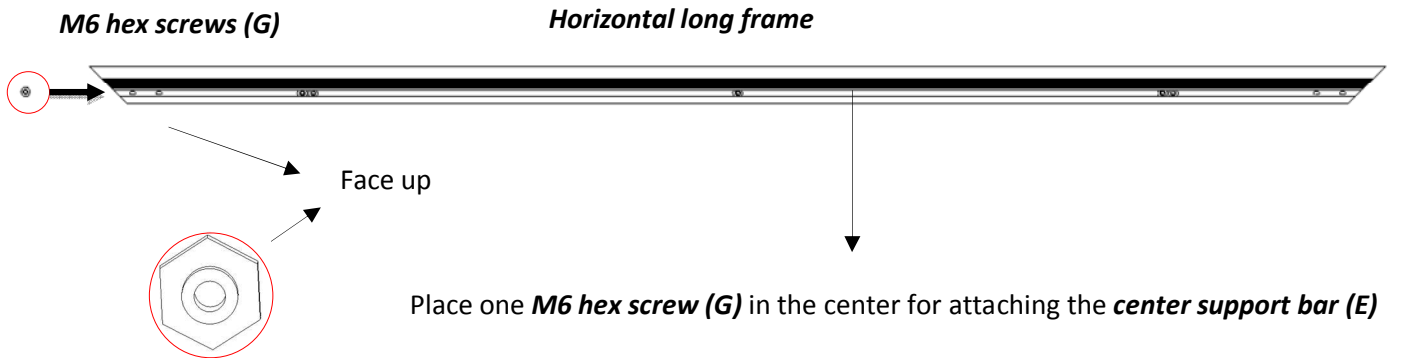

5. Insert the **elbow joint (A)** into each end of the **horizontal frames (B)** as shown below.

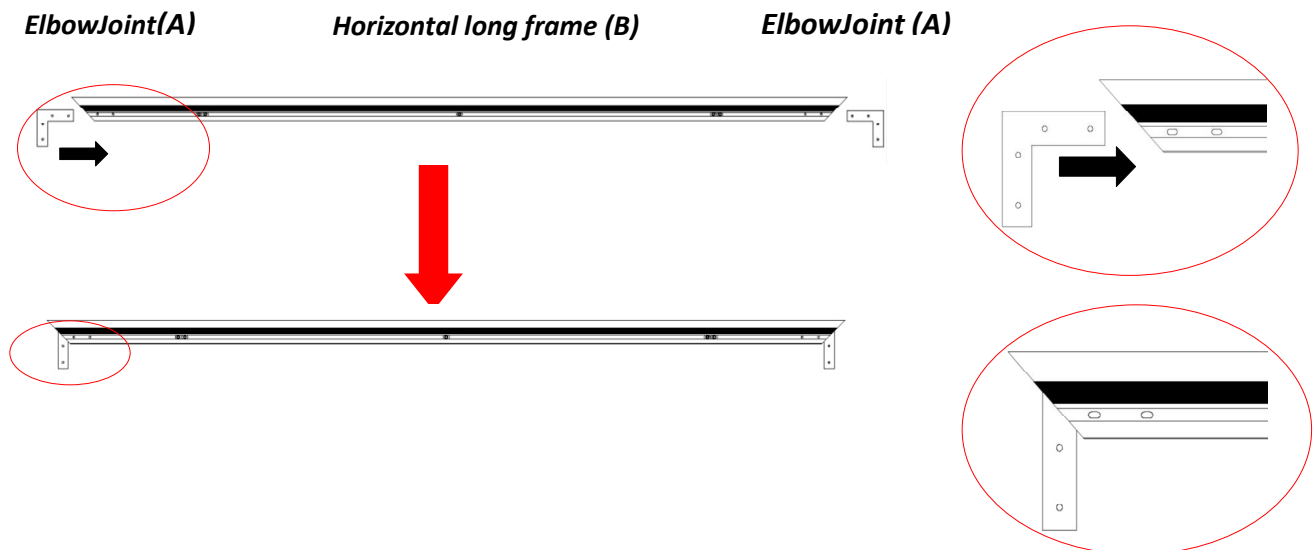

6. Insert the two **vertical short frames (C)** into the **elbow joint (A)**.

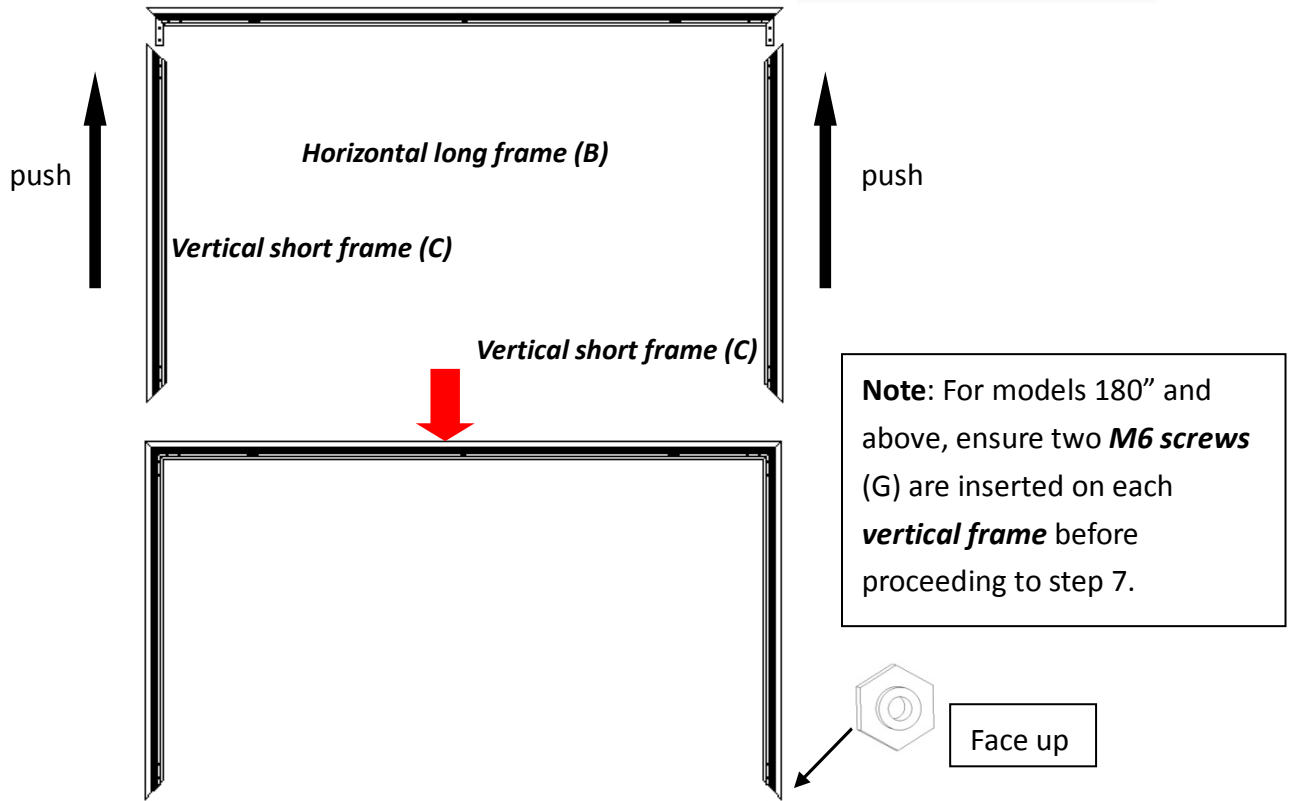

7. Join the remaining *horizontal long frame (B)* with the frame built in the previous steps as shown below.

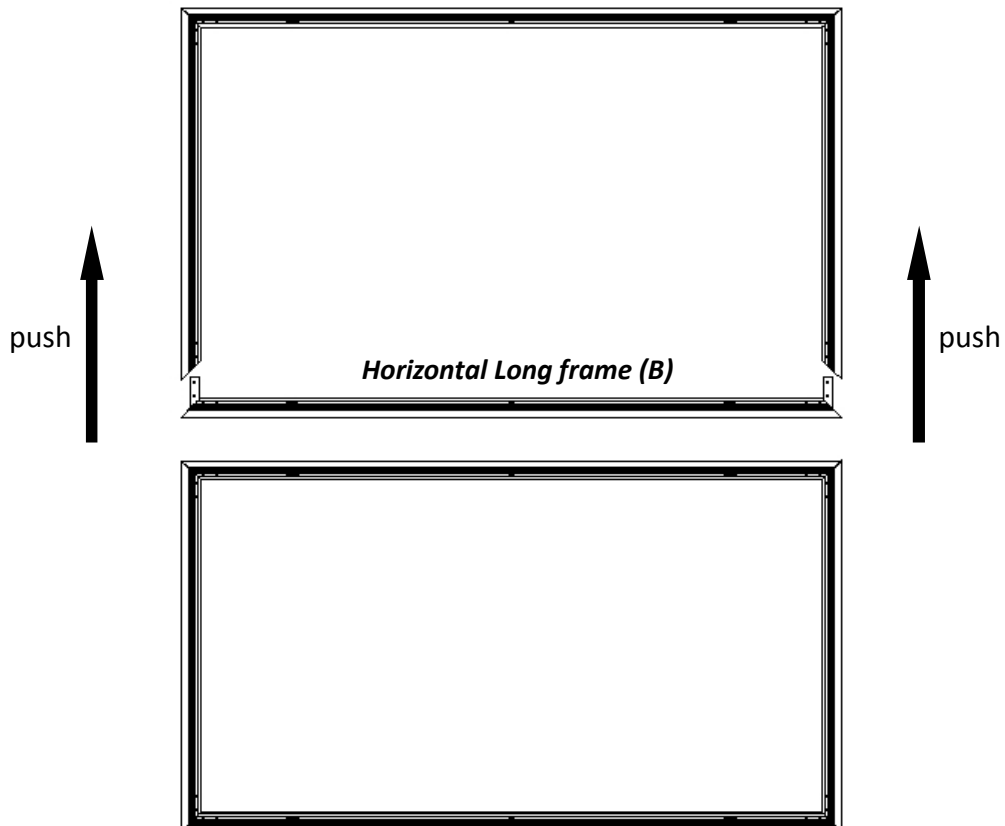

8. Make sure all four corners are properly in place to form a perfect square. Then fasten the four angles with the **M5x15 Screws (H)**.

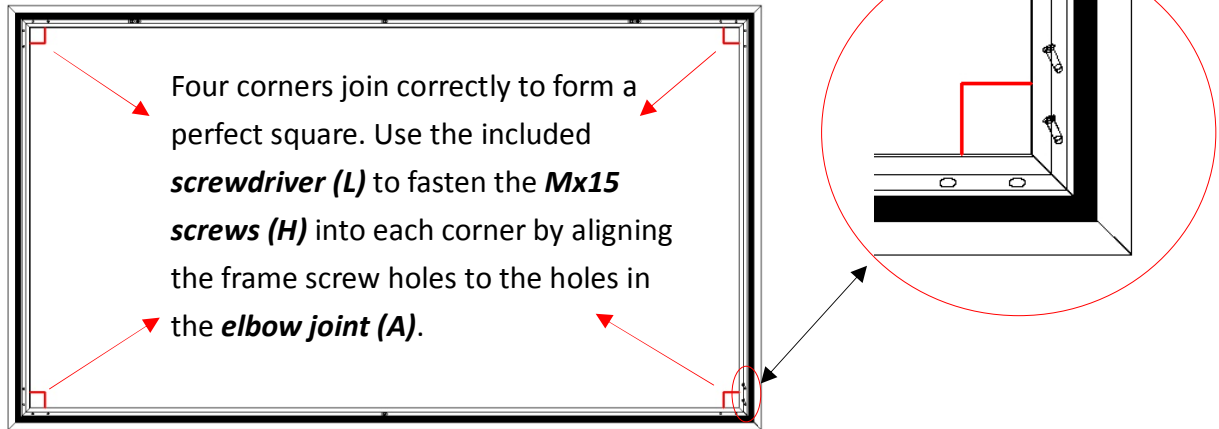

4.1.3 Screen Material Installation

1. Lay the **screen material** completely flat with the front facing down on a clean surface in a horizontal position. The back side of the screen material should be placed upwards.

Note: The back side of the material has the velcro borders all around the edges.

2. Carefully and gently place the assembled frame on top the screen material as shown below. Make sure to not allow the angle edge of the frame to come in direct contact with the screen material to avoid puncturing it.

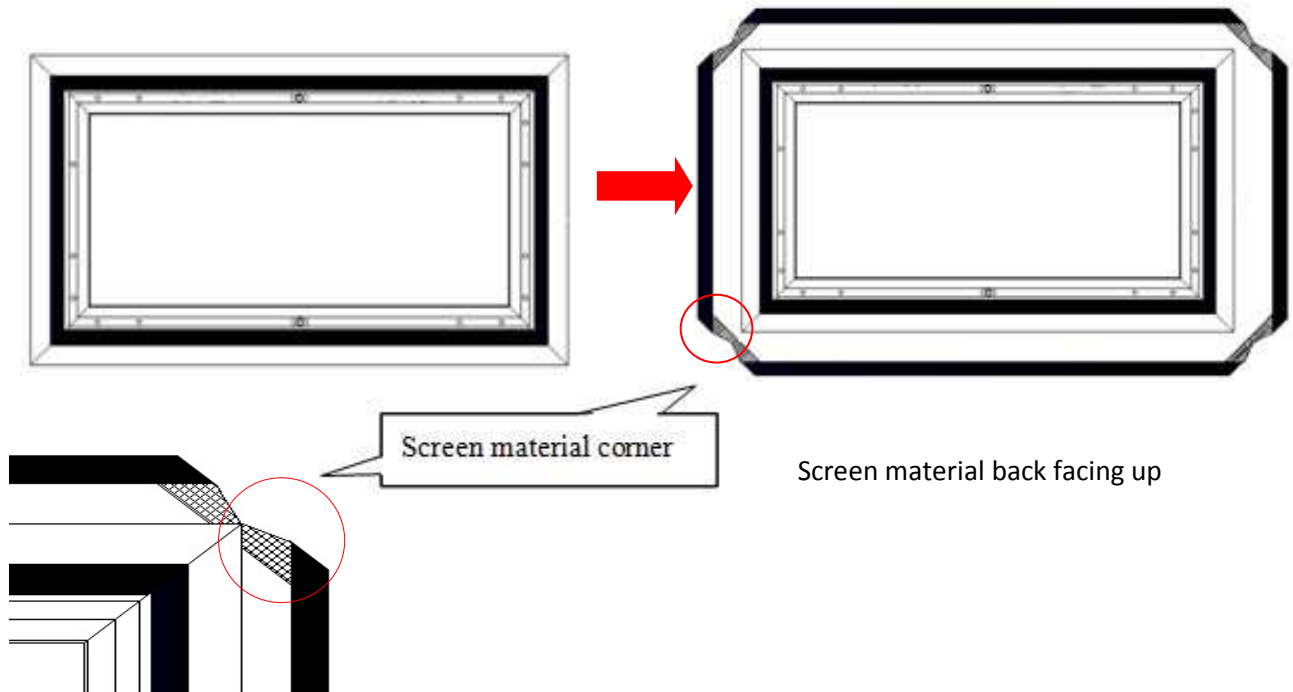

PRODUCT WHITE PAPER

<http://www.elitescreens.com>



3. After all of the corners of the frame have been properly aligned, attach the material to the frame in the following order A→B→C→D (see instructions below for details).

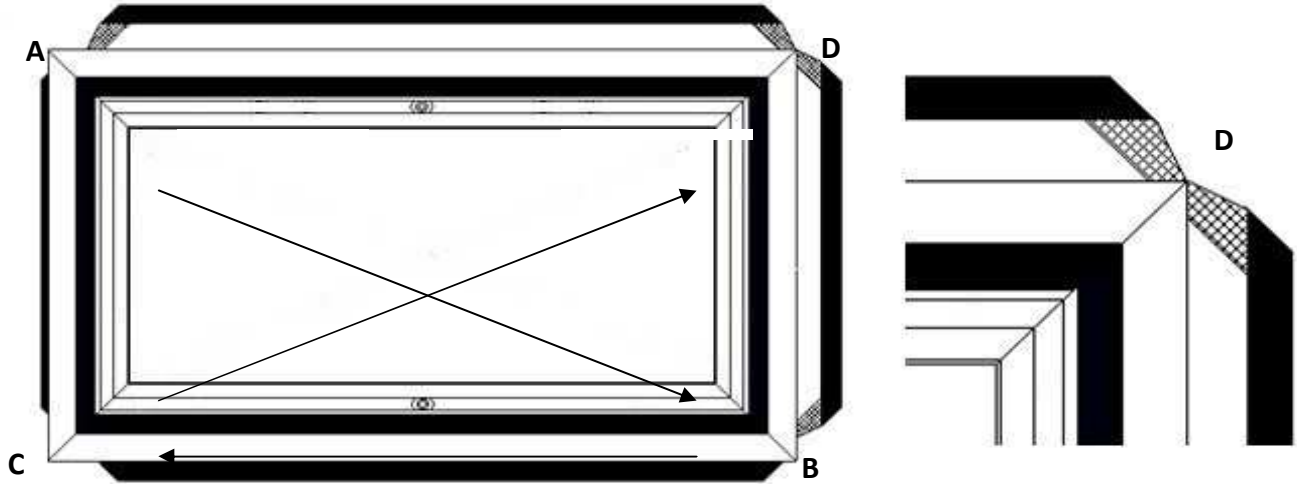

Attach the screen material to the corners as shown below.

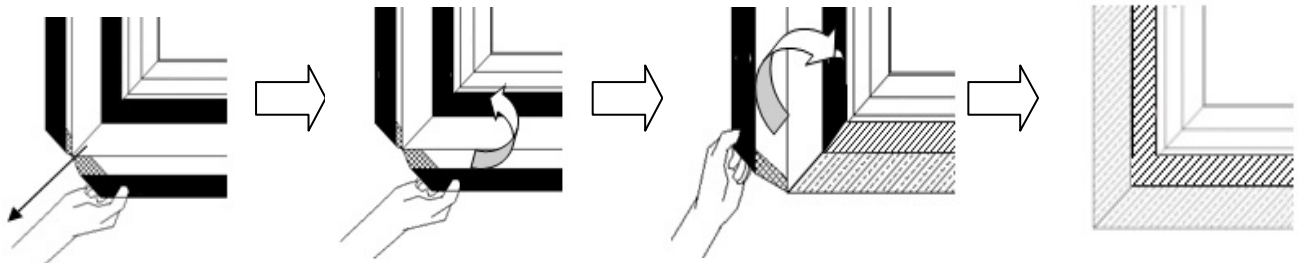

1) Stretch the screen material in the direction of the arrowhead.

2) Fold over and attach material to the velcro strip of the frame.

3) Fold over second side and attach to frame

4) Repeat until all four sides are done in the order A, B, C, D

4. After all four corners have been attached; please check whether the frame corners are wrapped by the screen material. If not, please loosen the velcro connection and repeat the above steps so the frame is not exposed.

Note:

Represents the screen material

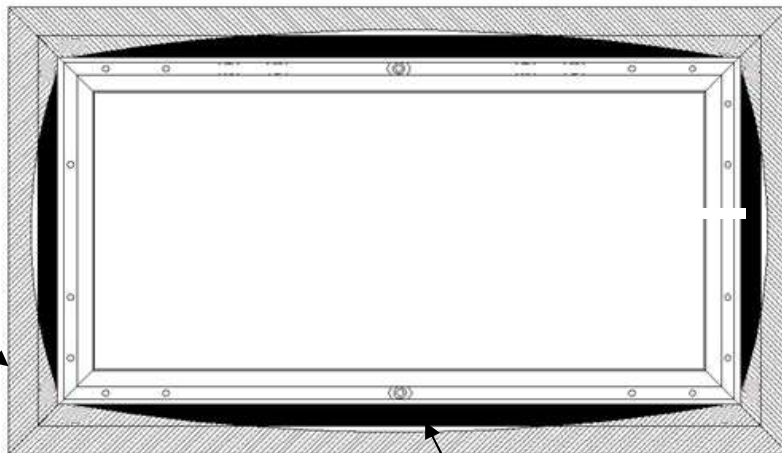

Note: The black shaded part represents the velcro on the frame. That Velcro end will ultimately attach with the other velcro end on the screen material.

5. Proceed to attach the rest of the material to the frame as described in the illustrations below.

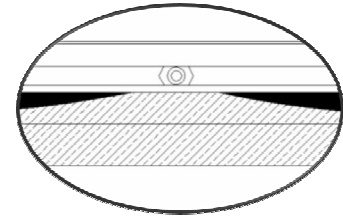
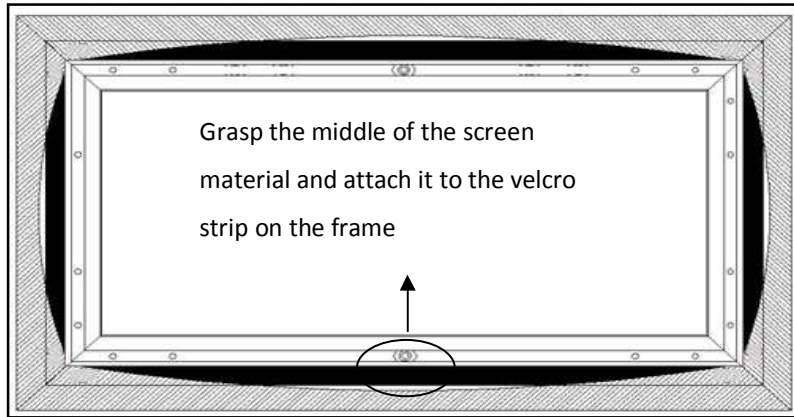

Lay the Velcro end on the screen material over the Velcro end of the frame and keep it within the edge.

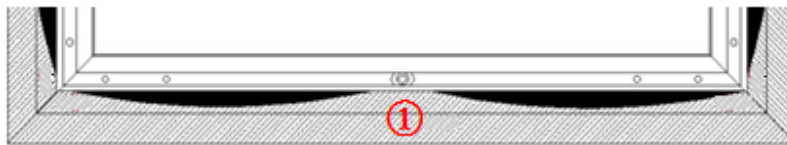

Proceed in the following sequence

below ① → ②



The key is to attach within the middle sections of 1 and 2. Then continue attaching the remaining unattached areas.

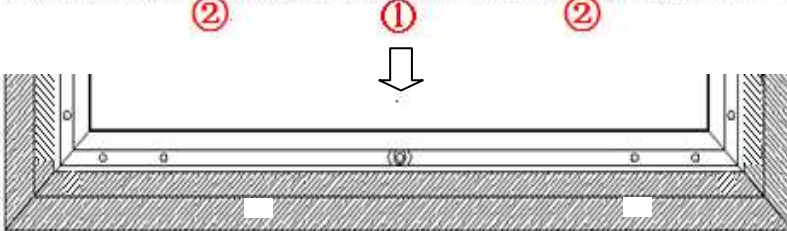

Repeat the same steps on remaining three sides in the sequence A, B, C, D as show below.

A

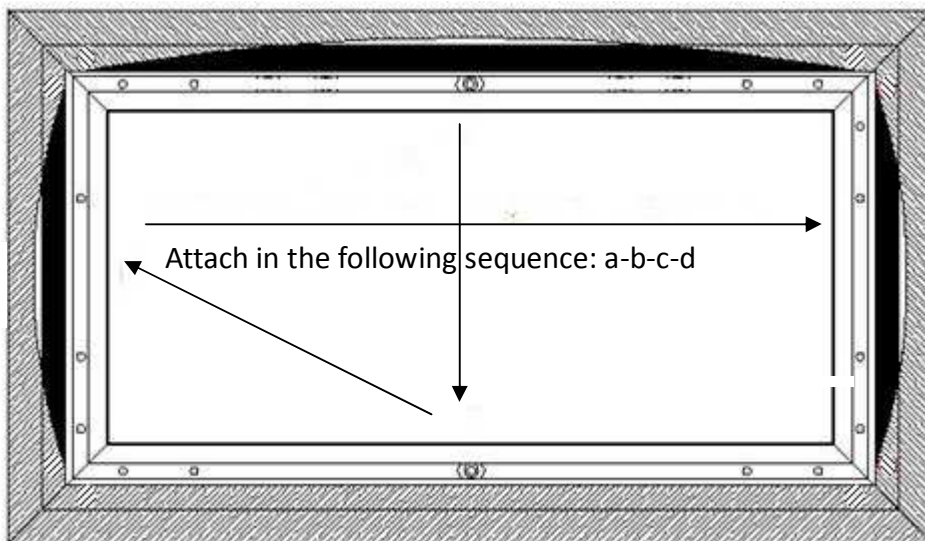

B

6. If the material is too loose or tight after adjusting all four corner sides, then you will need to reattach the material. *Please follow the steps below to properly remove the screen material from the frame. This procedure will ensure prolonging the life of the screen material.*

4.1.4 Screen Material Removal

1. Detach the velcro from the frame.
2. Gently pull back the material to release the material from the velcro connections on the corners.

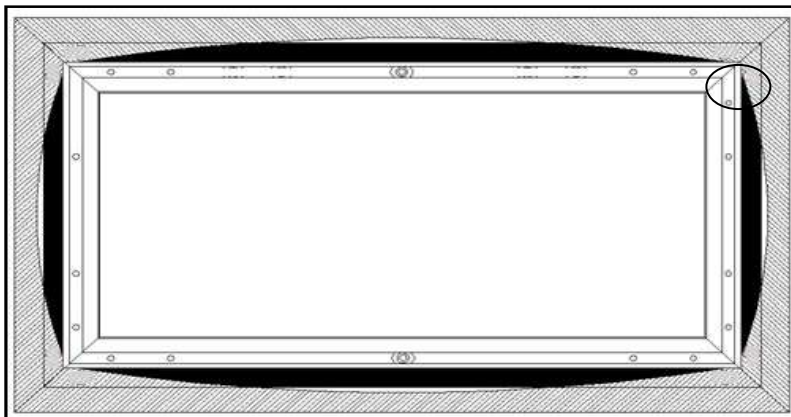

Pull back the screen material from the velcro connection along the edges of the frame to detach it.

4.1.5 Support Bar Installation (for models under 180")

1. Position the **center support bar (E)** in the middle of the frame and align the hole on each end of the support bar with the **M6 hex screws (G)** on the top and bottom frames. Then fasten with the **M6x12 screws (I)**.

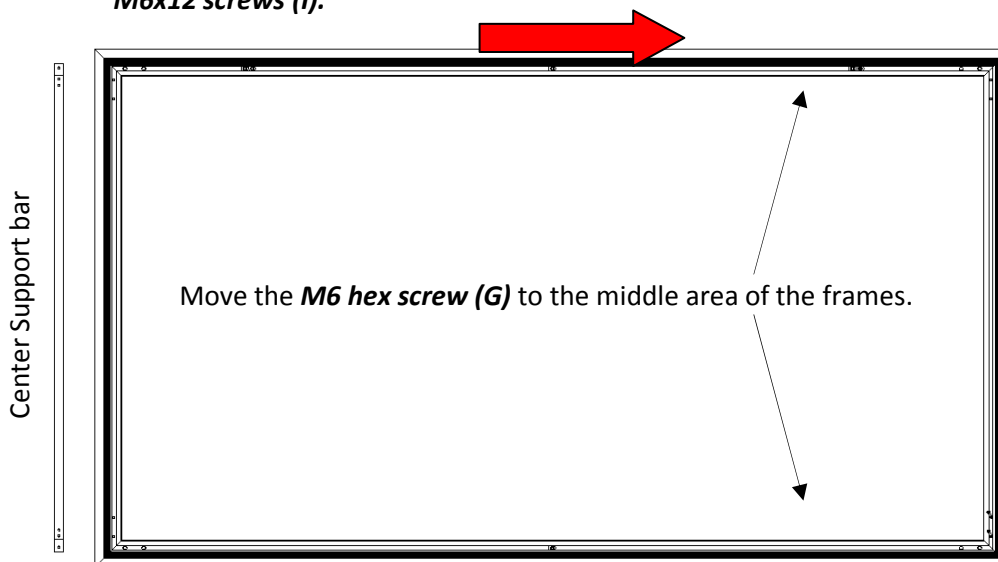

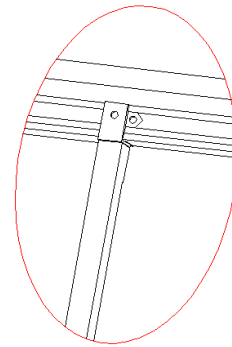
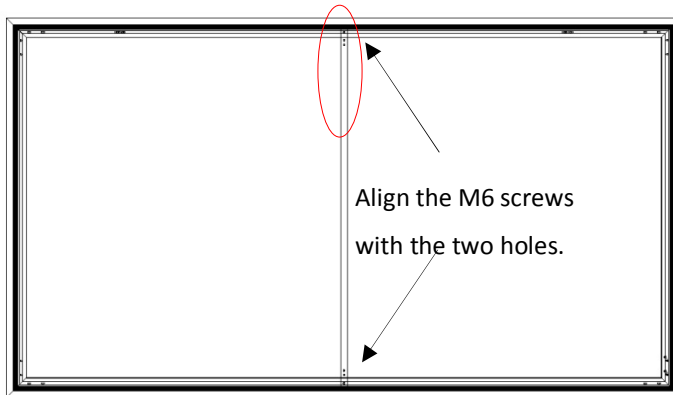

4.1.6 Support Bar Installation (for models 180" and above)

1. Position the **center support bar (E)** and **M6 hex screws (G)** in the areas of the frame shown in fig 1. Align the hole on each end of the support bar with the **M6 hex screws (G)** located at the top and bottom frame sections. Then fasten with the **M6x12 screws (I)**.

Center Support Bar

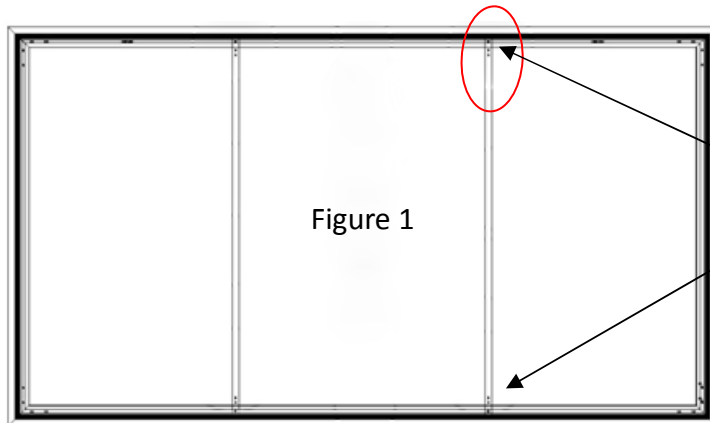
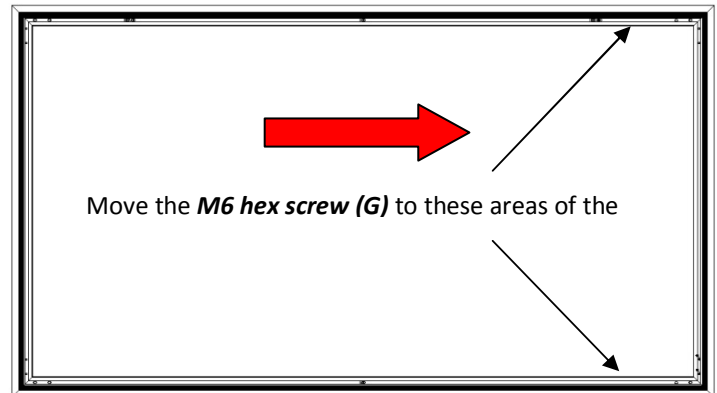
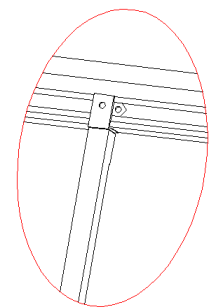
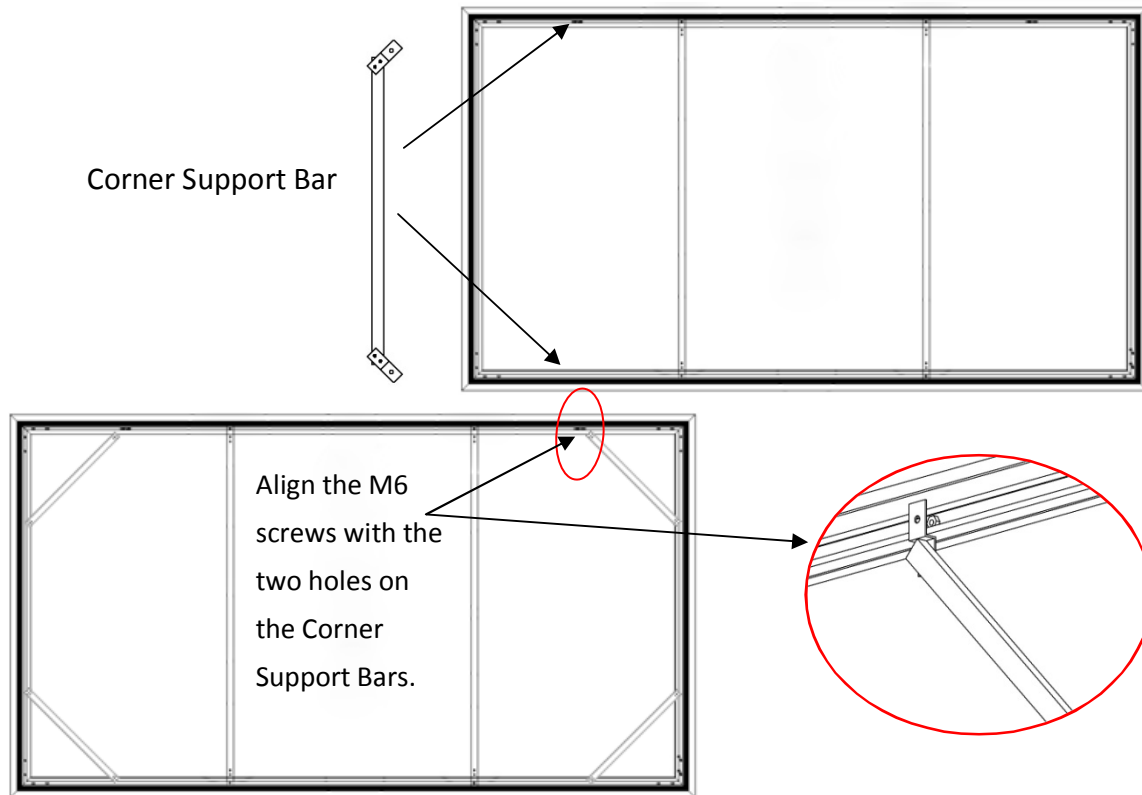

Figure 1

Align the M6 Screws with the two holes located on the Center Support Bar.



2. Position the **Corner support bars (N)** and **M6 Hex screws (G)** in the areas of the frame as shown below in fig 2. Align the holes on each end of the corner support bars with the M6 hex screws located on the vertical and horizontal frame sections. Then fasten with the **M6x12 screws (I)**.



Notice to Installer:

Please use the following installation instructions to obtain superior optical performance from the CineGrey 3D® Angular Reflective ALR (Ambient Light Rejecting) Screen.

Make sure to follow these instructions in order for the CineGrey 3D® to perform correctly.

- Angular-Reflective material is not compatible with ultra/short-throw projectors
- Minimum lens throw ratio 1.5x image width
- Ambient light must not come from the same direction as the projector

Since angular-reflective means that the projected image will reflect at the mirror-opposite angle, it is important to position the projector so that the viewer will get the best possible image.

Step 1: Establish the general “eye level” of the viewers

Step 2: Set the appropriate projection level

Step 3: Adjust the screen height level and projection angle

Input Angle (A) = Output Angle (B) aligns with the viewer's angle

Correct Installation Examples

Projector Ceiling Installation: Make sure the projector (*light in*) is angled (A) to reflect (B) at the mirror-opposite angle (*light out*) to align with the viewer's eye level.

Projector Table Top: Make sure the projector (*light in*) is angled (A) to reflect (B) at the mirror-opposite angle (*light out*) to align with the viewer's eye level.

Incorrect Installation Examples

Ceiling Mounted Short-throw Projector

Tabletop Ultra-Short throw Projector

Note: Improper installation will result in light loss and produce a dark image. This is due to the projector's light reflecting in the wrong direction. *Images are not up to scale and are for illustration purposes only.*

4.1.7 Velvet Tape Trim Installation

Attention: Installing the velvet trim will reduce the viewing size of your screen. See below illustrations for a comparison of the viewing size of the before and after edge trim installation using the 100" & 120" 16:9 diagonal models.

100" comparison:

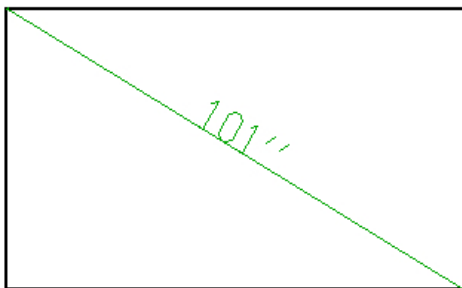

Before installing the trim

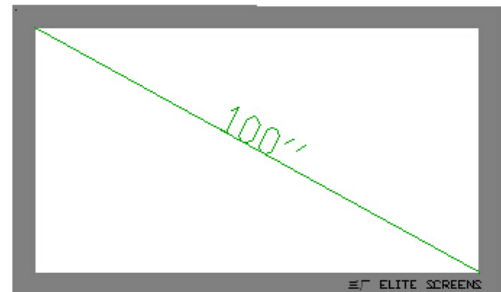

After installing the trim

PRODUCT WHITE PAPER

<http://www.elitescreens.com>



120" comparison:

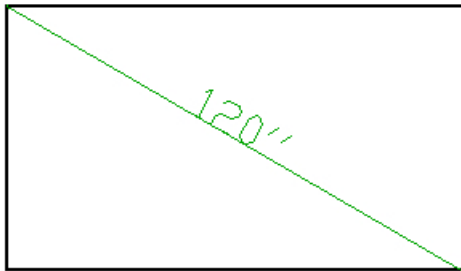

Before installing the trim

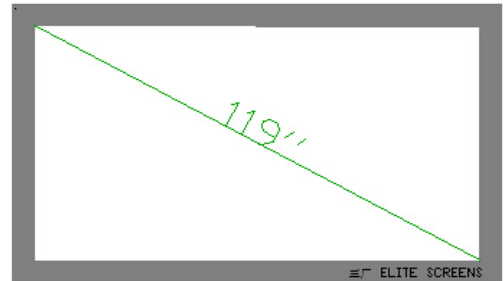

After installing the trim

1) Lay the assembled frame on its back on a clean surface.

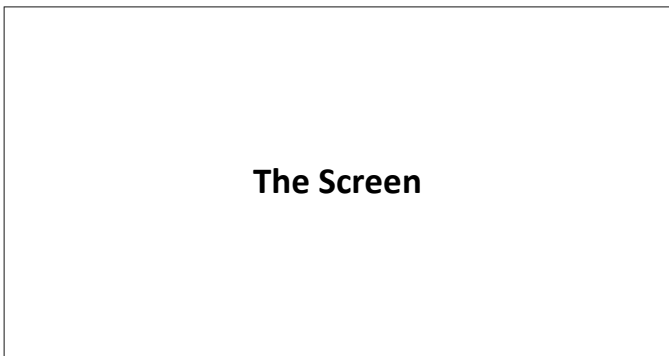

2) Measure 10 mm (0.40") from the edge of the frame to the inside of the material.

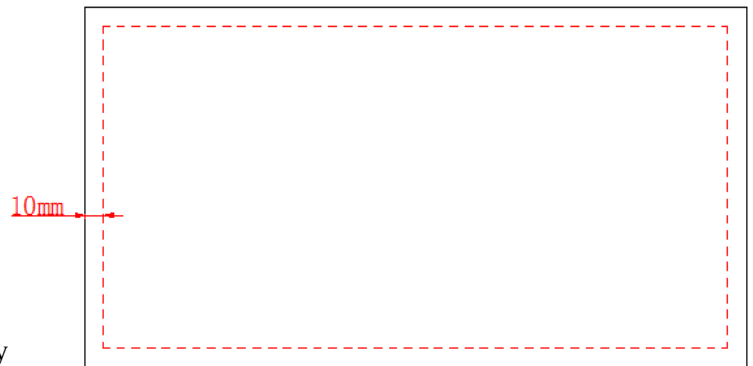
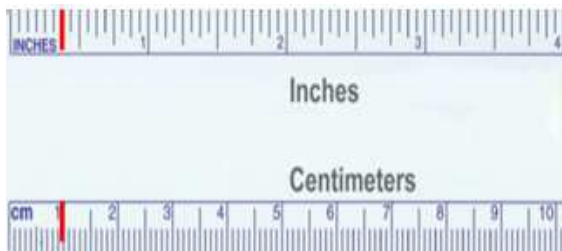

3) Make a light mark with a pencil approximately making a straight line for the velveteen strip.

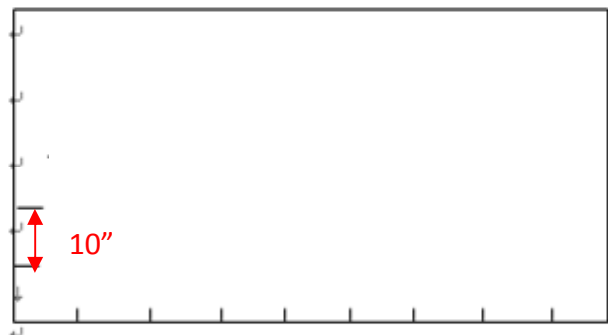
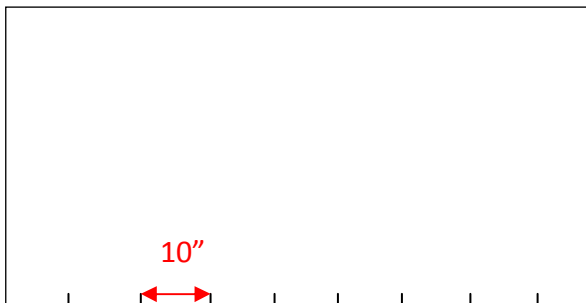

- 4) Repeat steps 2 and 3 on the remaining sides
- 5) Peel off the backing on the velvet strip and align the top edge at the 10mm mark.



- 6) Continue peeling off the backing until the other side has been reached. Make sure that the velvet strip is kept straight the entire way.
- 7) Fold back the excess unused velveteen.

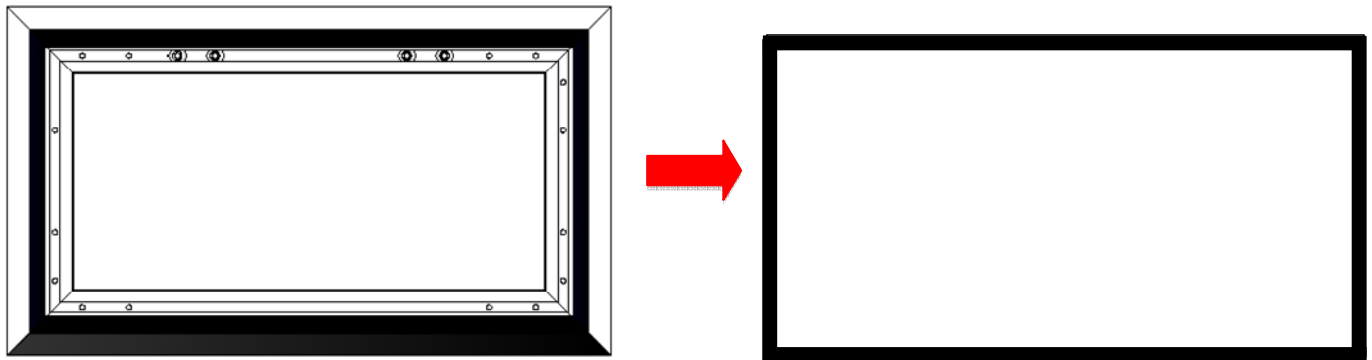

- 8) Repeat steps 5-7 to complete the velveteen strip installation.

4.1.8 Installation

Locate your desired installation location with a stud finder (recommended) and mark the drill-hole area of where the screen is to be installed.

1. Drill a hole with the proper bit size according to the wood screws included.
2. Line up the wall brackets with the drilled holes on the installation location and screw them in using a Phillips screwdriver.
3. Position the frame screen onto the **wall brackets (F)** as shown in **below**.
4. The design of the wall brackets allows the frame to slide over them through its sides. This is an important feature of the installation design as it allows your screen to be properly centered.

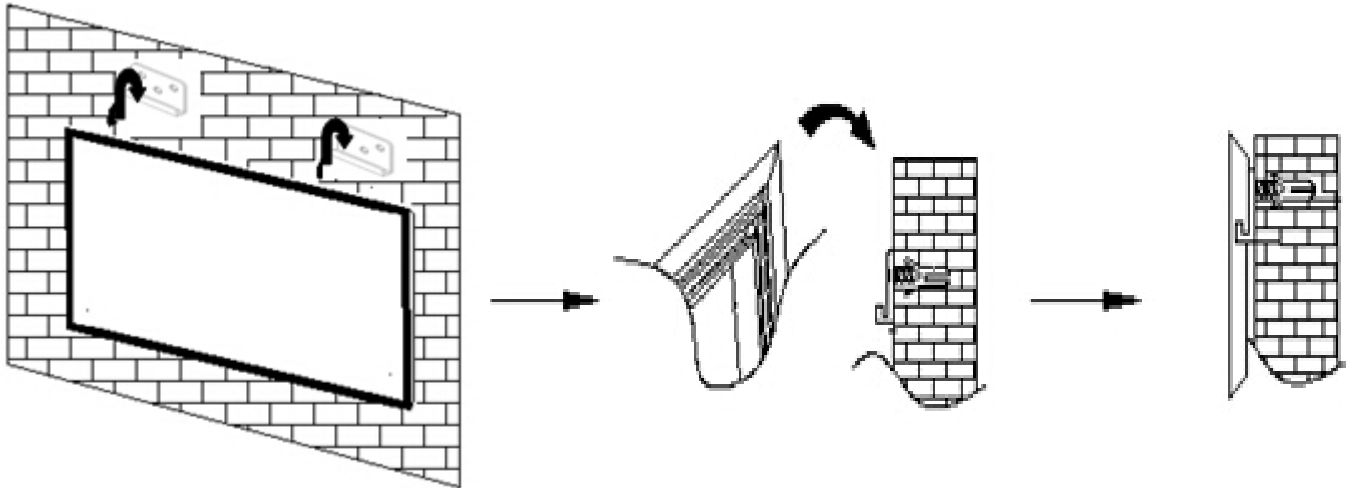





4.2 Spring Type User Guide

4.2.1 Screen Material Maintenance and Cleaning

In order for the *CineGrey 3D* to maintain its projection qualities and optimum performance, please refer to the list below for proper maintenance and cleaning.

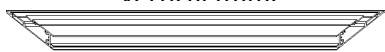
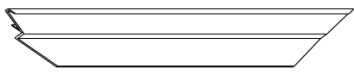
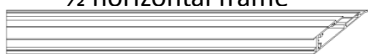
- Use a dry microfiber cloth to remove dust from the screen’s surface.
- When cleaning, use a damp microfiber cloth with warm water to remove any marks.
- Never rub or apply pressure when cleaning the surface.
- Never attempt to use any solutions, chemicals or abrasive cleaners on the screen surface.
- In order to avoid damaging the screen, avoid touching it directly with your fingers, pens/pencils or any other sharp or abrasive objects.

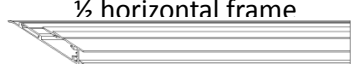



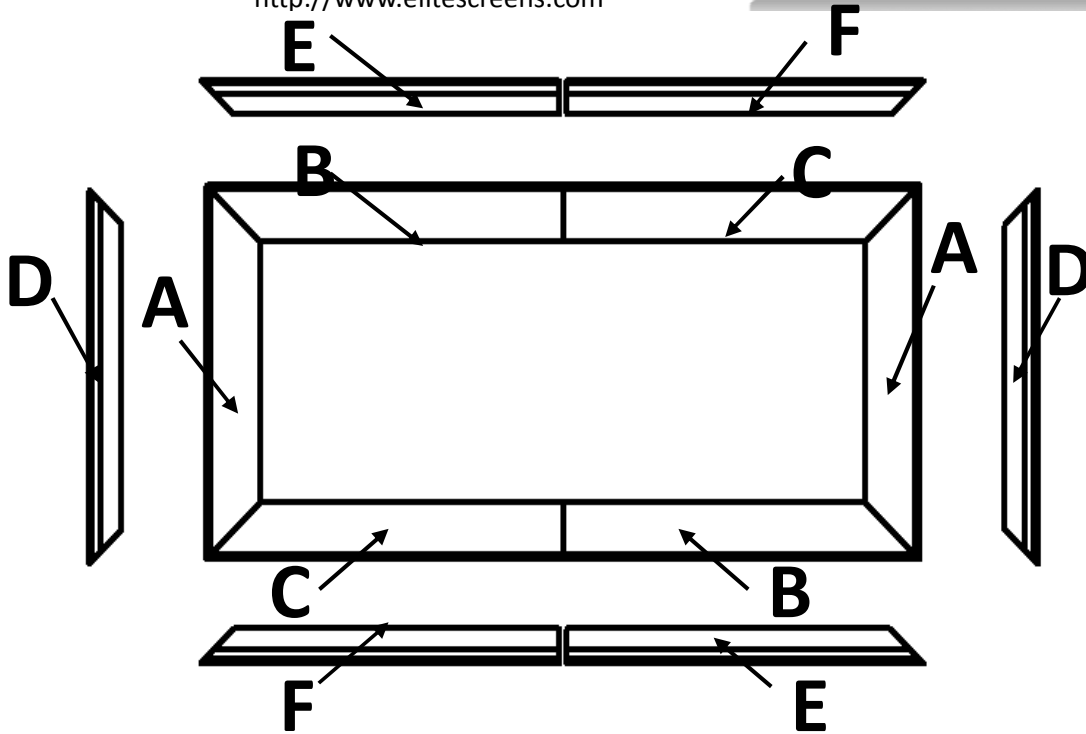

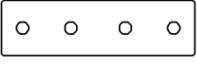
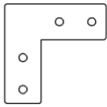

4.2.2 Parts Lists

1. Frame and Edge Trim Parts List			
Qty item	2 pcs Main Frame Parts	Qty item	2 pcs Edge Trim Parts
Part A.	vertical frame 	Part D.	
Part B.	½ horizontal frame 	Part E.	
Part C.	½ horizontal frame 	Part F.	

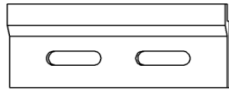

2. Hardware Parts Quantity List

Item	Parts List	84H	100H	110H	120H	135H	150H	103C	125C	138C	158C
a.	Center Joints (1)	4	4	4	4	4	4	4	4	4	4
b.	Elbow Joints (2)	8	8	8	8	8	8	8	8	8	8
c.	M4x6 Screws	60	60	60	60	60	60	60	60	60	60
d.	Spring Hook	2	2	2	2	2	2	2	2	2	2
e.	Spring	72	92	96	104	116	128	88	104	116	134
f.	Top wall brackets	2	2	2	2	2	2	2	2	2	2
g.	Ø5x50 Wall Screws	6	6	6	6	6	6	6	6	6	6
h.	Hollow Wall anchors	6	6	6	6	6	6	6	6	6	6
i.	Bottom wall brackets	2	2	2	2	2	2	2	2	2	2
j.	Angle cover	4	4	4	4	4	4	4	4	4	4
k.	M4x7 Screws	8	8	8	8	8	8	8	8	8	8
l.	Center Support Bar	1	1	1	1	1	1	1	1	1	1
m.	White gloves	2	2	2	2	2	2	2	2	2	2

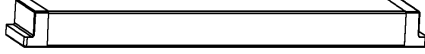
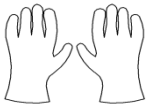
2. Hardware Parts List			
a. 	b. 	c. 	d. 
e. 	f. 	g. 	h. 
i. 	k. 	l. 	m. 

4.2.3 Frame Assembly

Step 1: Place the soft padded EPE sponge on clean area on the ground where the screen will be assembled.

Step 2: Position the pieces of the frame on the EPE sponge in the arrangement shown below

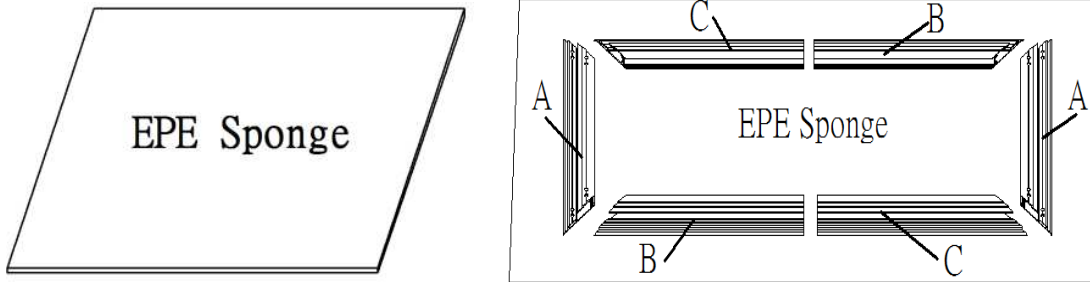

Step 3: Remove the tape on all frame ends before assembling the frame.

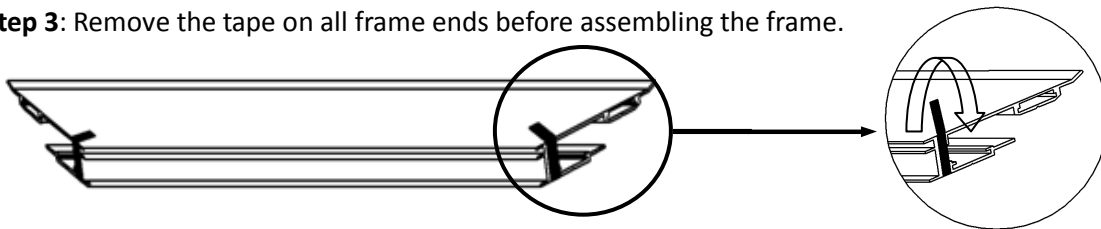

Step 4: Insert the *center joint (a)* connectors into *one-half of the horizontal frame (b/c)* and secure with the *M4x6 screws (c)*.

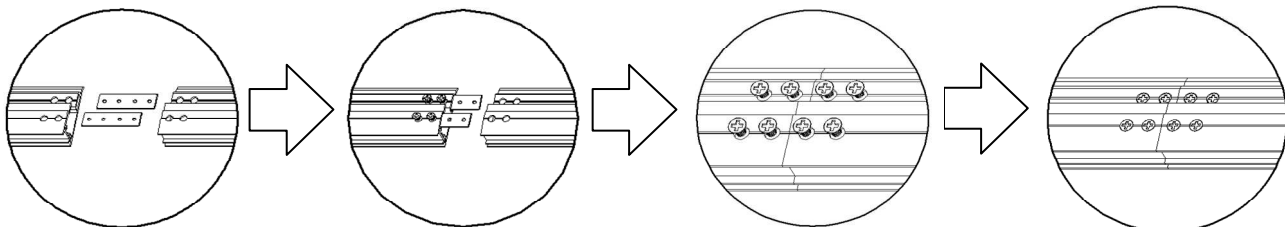

Step 5: Insert the **springs (e)** into the grooves of the frame. The spring's hooks should be facing the front side of the frame. For the correct amount of springs to place into the frame, please refer to the table listed below.

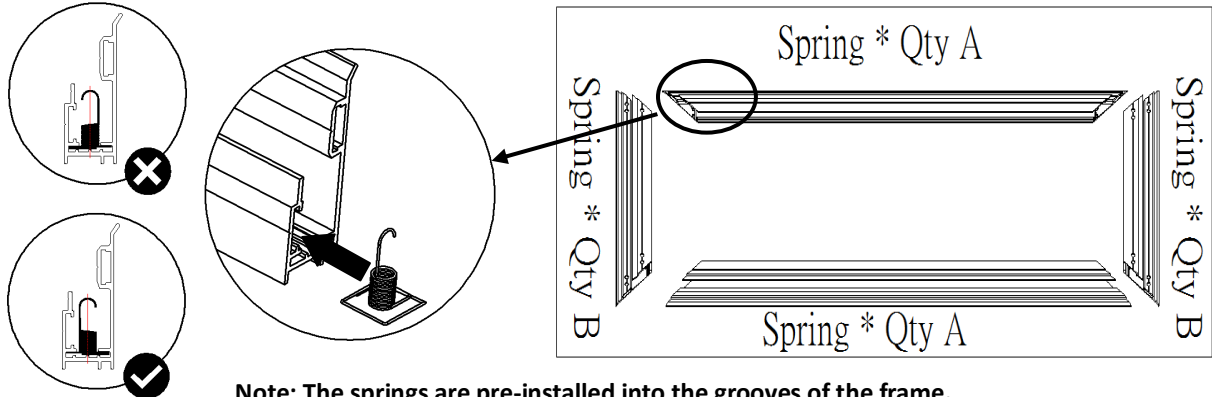

Note: The springs are pre-installed into the grooves of the frame.

Screen Size		84H	100H	110H	120H	135H	150H	103C	125C	138C	158C
Spring Qty	A	23	29	31	33	37	41	31	37	41	47
	B	13	17	17	19	21	23	13	15	17	20

Step 6: Connect the **elbow joints (b)** to the top and bottom sections of the vertical frame. Once inserted, connect the vertical sections of the horizontal frame sections. Make sure all holes are in alignment and the frame pieces are flush (no gaps). They should form perfect right angles.

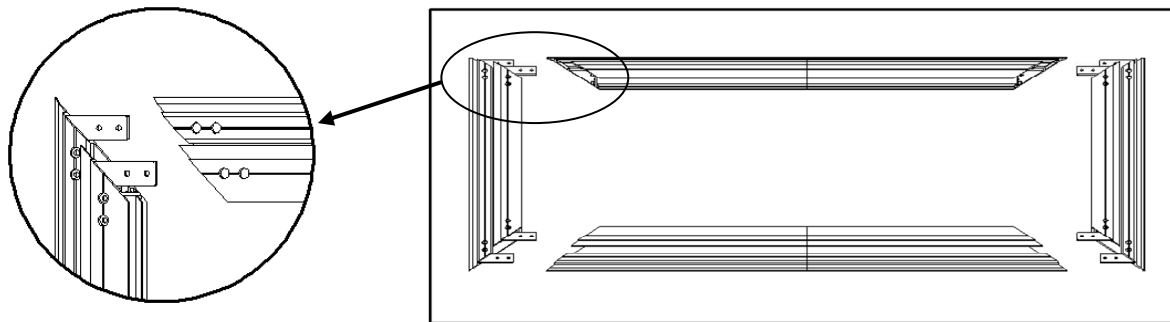

Step 7: Secure the elbow joints by fastening them with **M4x6 screws (c)**, 4 at each corner.

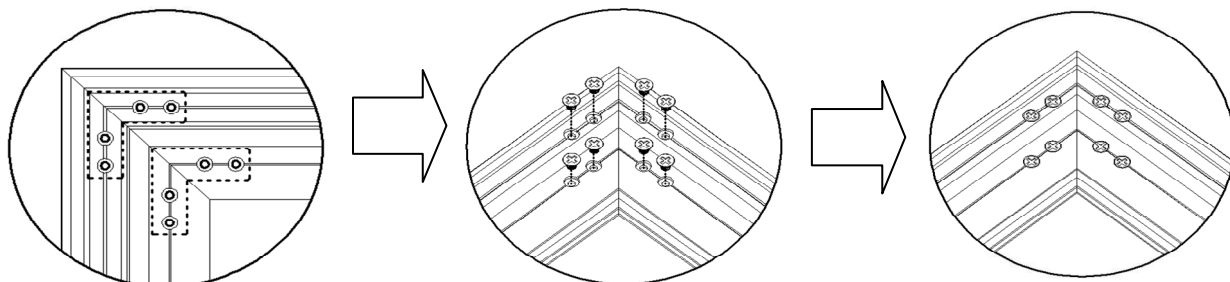

4.2.4 Screen Material

Step 8: Put on the **white gloves** (m) and carefully unroll the screen material on a clean surface from the roller to the other side as shown below. The back side of the screen material should be placed upwards.

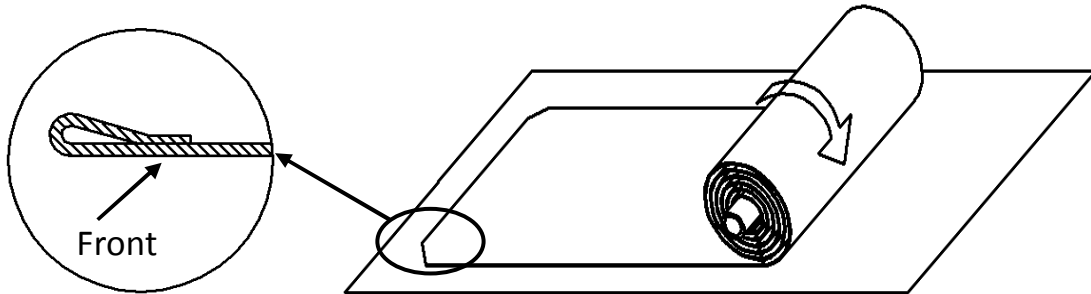

Step 9: Carefully and gently place the assembled frame on top of the screen material. Make sure to not allow the angle edge of the frame to come in direct contact with the screen material to avoid puncturing it.

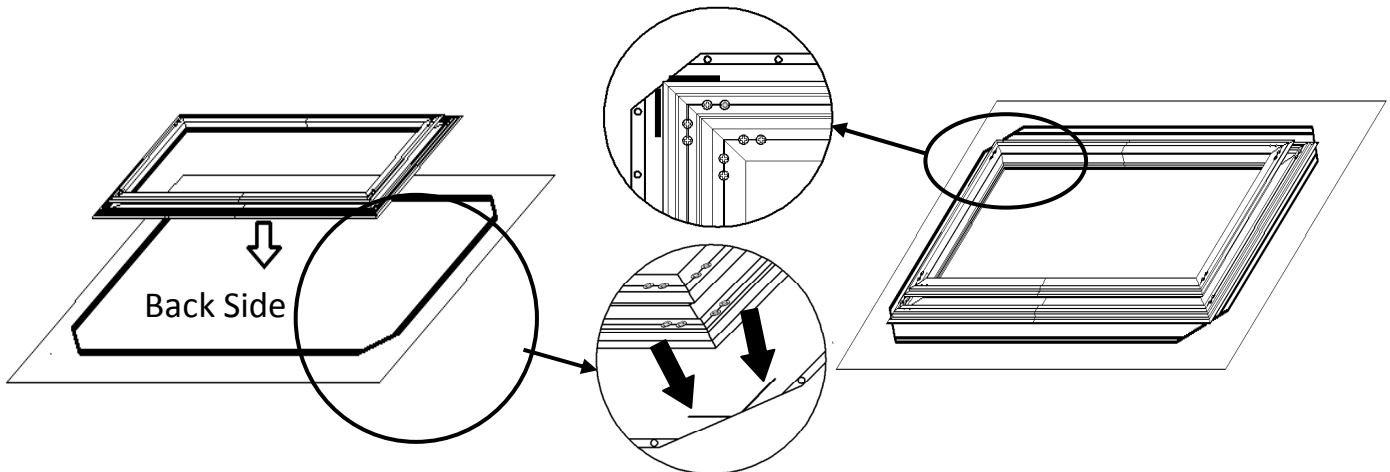

Step 10: With one end of the spring and secure inside the groove of the frame, use the **spring hook (d)** to attach the spring to the hole located on the screen material's outer edge in the following order.

Attach the four corners first (1). After those are secure, connect the vertical portions of the material, begin in the center and move towards the corners (2). Lastly, connect the horizontal sections of the material by connecting the center of the material and make your way towards the corners (3).

Note (after all springs have been attached):

Correct material installation –Corners of the screen material are properly wrapped around the corner edges of the frame and material is evenly tensioned and flat, creating a nicely taut surface.

Incorrect material installation –The corners of the screen material are not properly wrapped along the edge of the frame leaving the material with unbalanced tension and an uneven finish. To correct, detach springs from material at the corner(s) where material does not lie flat along the edge of the frame, reposition the material so that it lies flat and wraps along the edge of the frame, and reattach springs to the material.

Note: Please make note of the yellow label and spring in the center of the frame. This is an indicator to start the screen material installation process from the middle area of the frame.

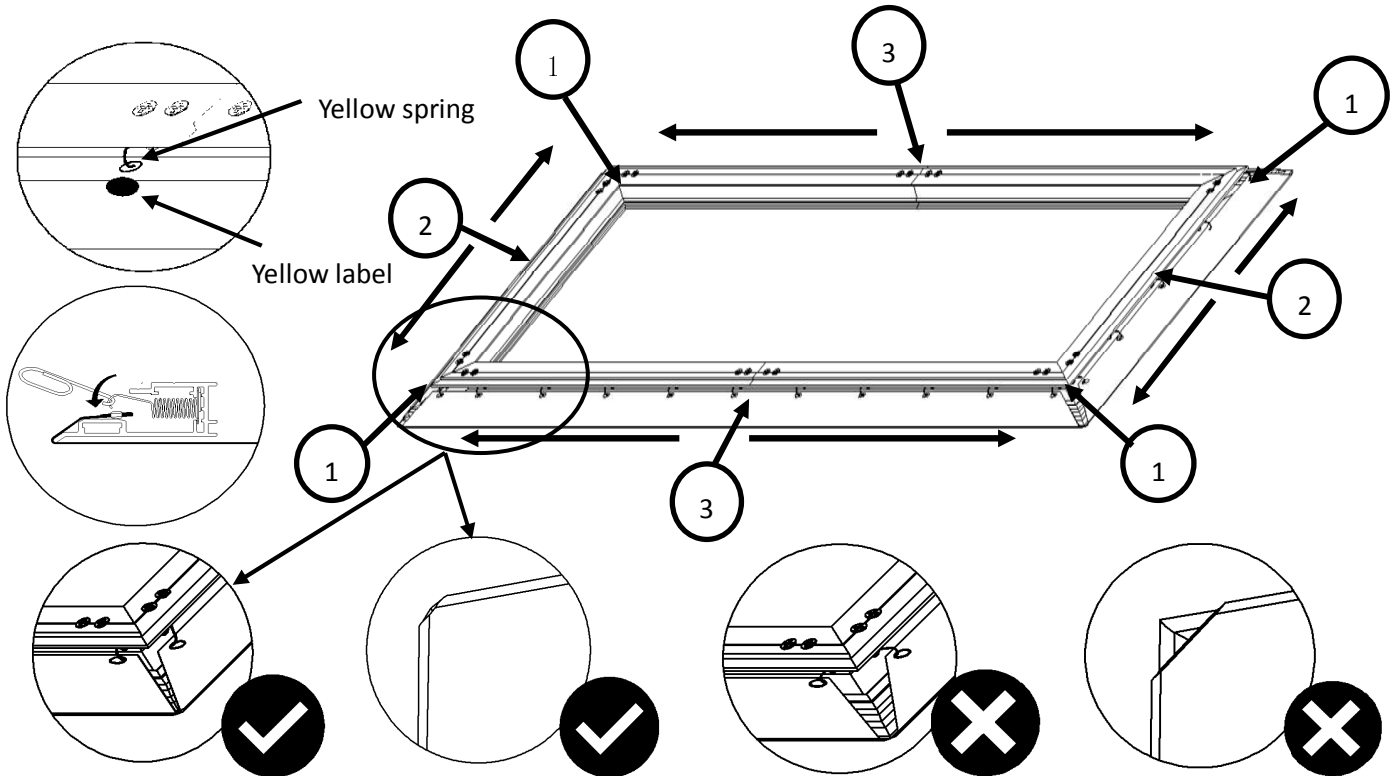

To avoid ripples forming in the material it is imperative that all of the corners are properly wrapped around the edges as illustrated in the check mark diagrams.

4.2.5 Center Support Bar

Step 11: Insert the **Center Support Bar (i)** into the upper top groove on the back of the frame with the bottom end near the approximate center point of the frame and rotate it in at an angle so that both ends of the bar are in alignment with the groove.

Diagonal Models 150" and below use 1 x Center Support Bar

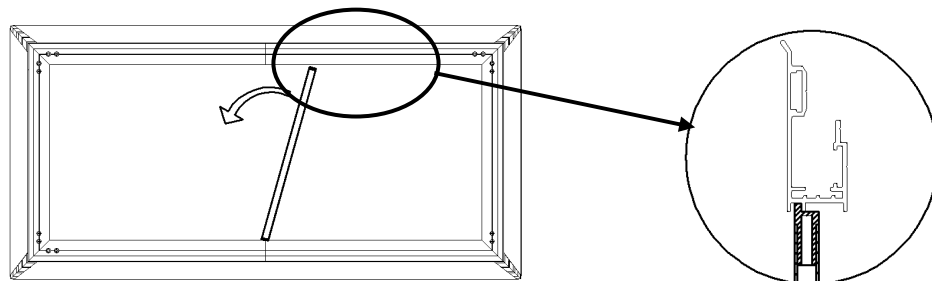

Diagonal Models above 150" require 2 x Center Support Bars

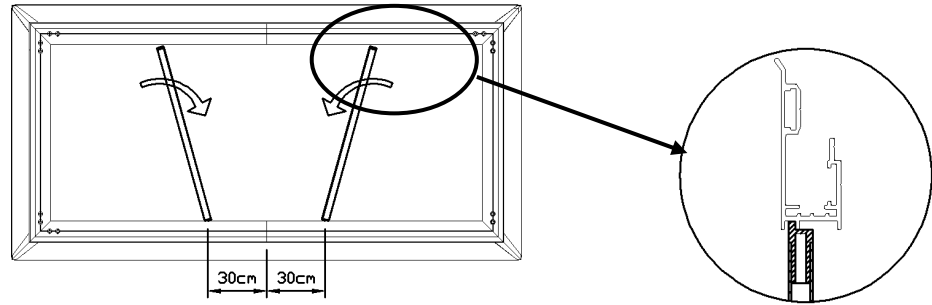

Attention: Do not proceed with the Edge Trim installation until making sure there are no ripples in the material.

4.2.6 Edge Trim Installation

Step 12: Place the **Edge Trim** over each end of the frame and secure with **M4x6screws (c)**.

Start with the center points first, then the rest of the corners as shown below.

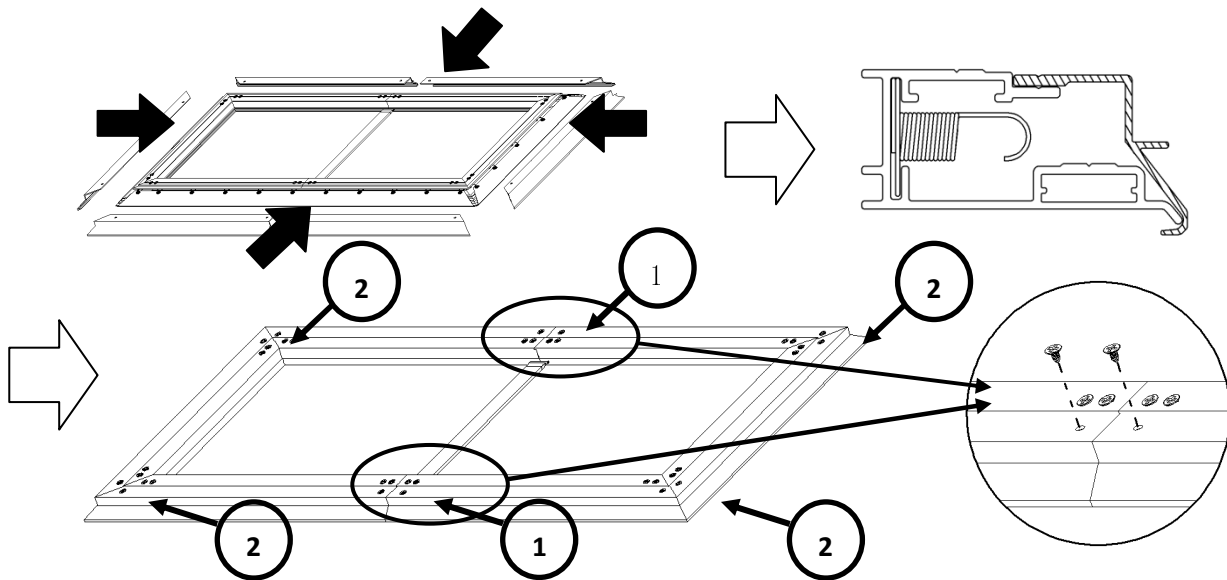

Step 13: Install the **angle cover (j)** on each corner of the frame and install the M4x7 screws to hold down the angle cover.

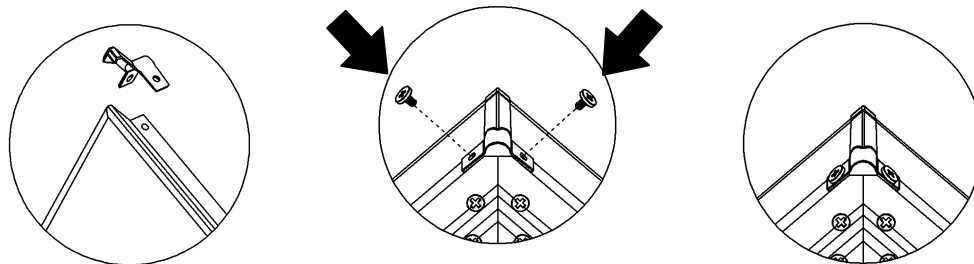

Notice to Installer:

Please use the following installation instructions to obtain superior optical performance from the CineGrey 3D Angular Reflective ALR (Ambient Light Rejecting) Screen.

Make sure to follow these instructions in order for the CineGrey 3D to perform correctly.

- Angular-Reflective material is not compatible with ultra/short-throw projectors
- Minimum lens throw ratio 1.5x image width
- Ambient light must not come from the same direction as the projector

Since angular-reflective means that the projected image will reflect at the mirror-opposite angle, it is important to position the projector so that the viewer will get the best possible image.

Step 1: Establish the general “eye level” of the viewers

Step 2: Set the appropriate projection level

Step 3: Adjust the screen height level and projection angle

Input Angle (A) = Output Angle (B) aligns with the viewer’s angle

Correct Installation Examples

Projector Ceiling Installation: Make sure the projector (*light in*) is angled (A) to reflect (B) at the mirror-opposite angle (*light out*) to align with the viewer’s eye level.

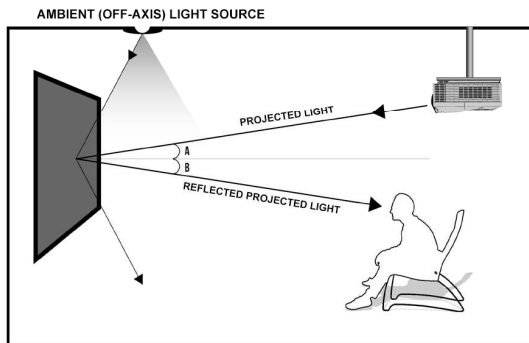

Projector Table Top: Make sure the projector (*light in*) is angled (A) to reflect (B) at the mirror-opposite angle (*light out*) to align with the viewer’s eye level.

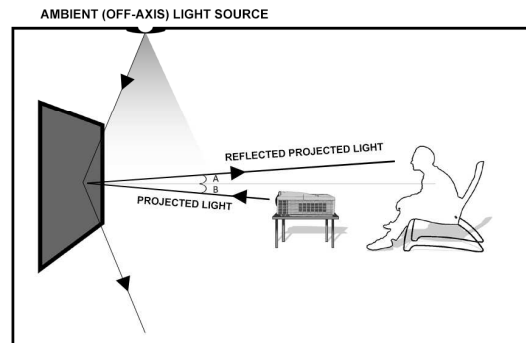

Incorrect Installation Examples

Ceiling Mounted Short-throw Projector

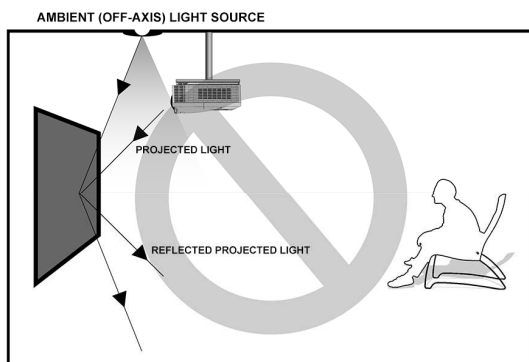

Tabletop Ultra-Short throw Projector

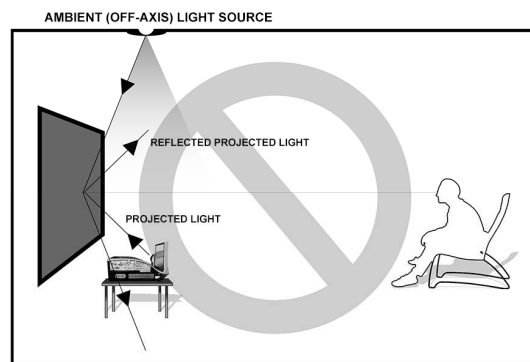

Note: Improper installation will result in light loss and produce a dark image. This is due to the projector’s light reflecting in the wrong direction.

Images are not up to scale and are for illustration purposes only.

4.2.7 Wall Installation

Step 14: Measure the overall length and height of the frame and drill holes for the top brackets. Line up the wall brackets with the drilled holes on the installation location and screw them in using a Phillips screwdriver. If not installing into a structural wood stud, use a hollow wall anchor then screw in the M5x50 wood screws with a screwdriver. Make sure the brackets are leveled.

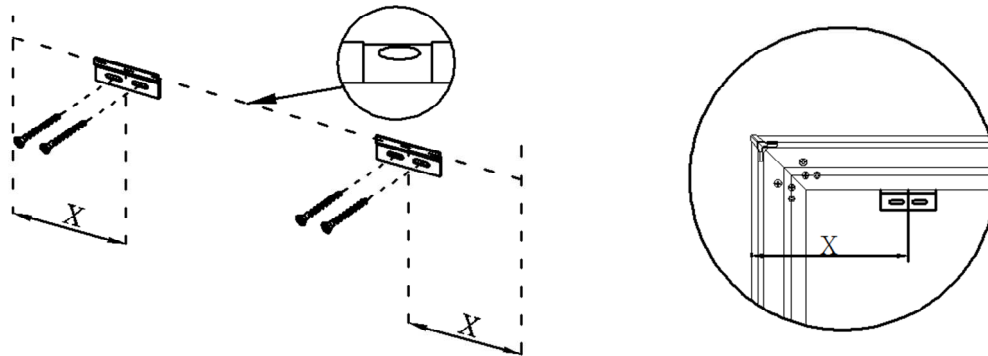

Step 15: Position the fixed frame screen onto the top wall brackets as shown below and push down at the center of the top of the frame to secure.

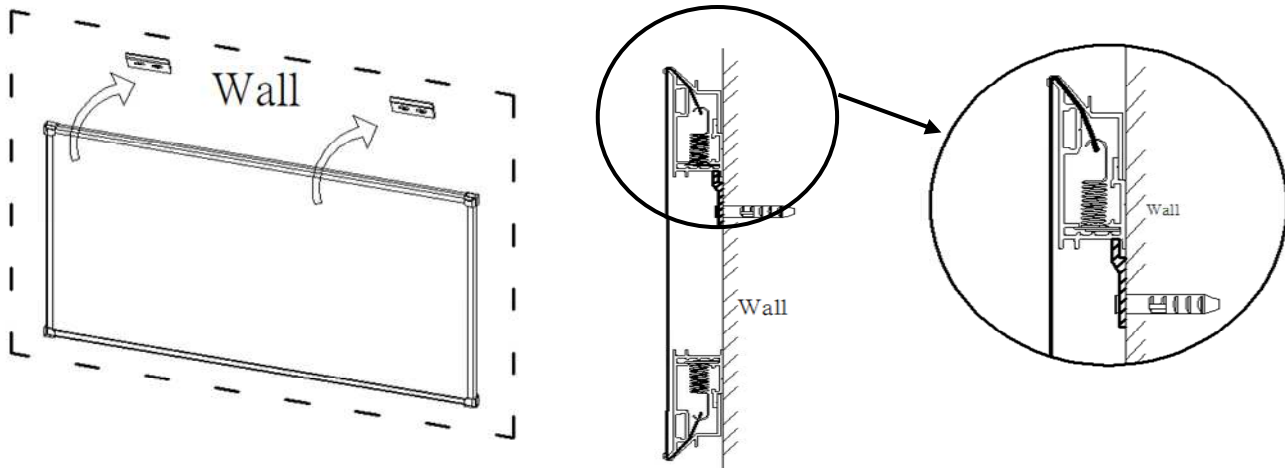

Step 16: With the frame slightly tilted outward; connect the bottom brackets onto the bottom groove of the frame. Then secure them by screwing onto the wall

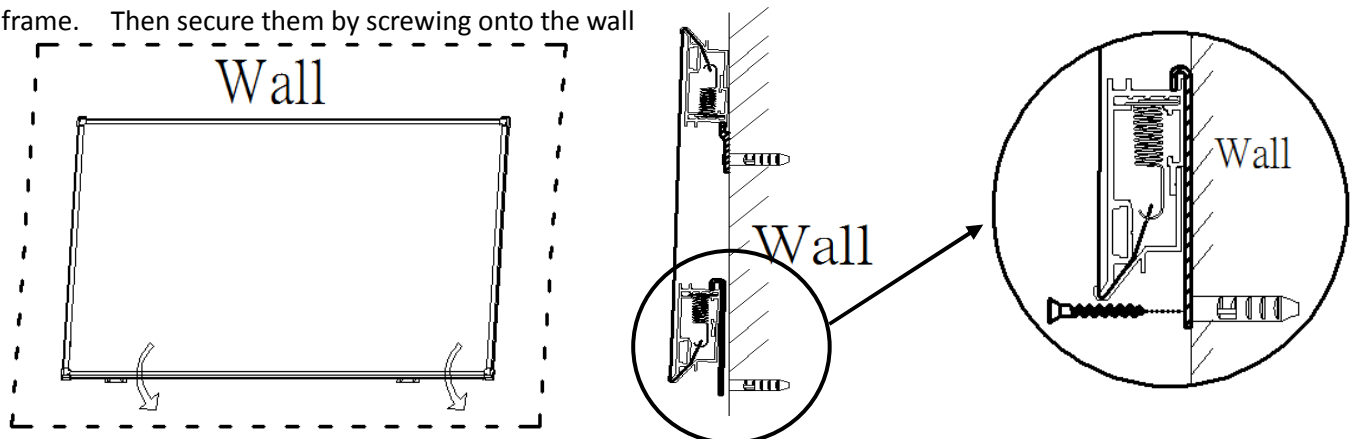

Section 5: Product Specifications

5.1 Dimensions

5.1.1 Aeon Dimensions

Model	Diag. Size	Aspect Ratio	Frame Length (A)	View Width (A1)	Overall Frame H. (B)	View Height (B1)	Frame Width (C)	Frame Depth (D)
Unit: Inches								
AR92WH2	92"	16:9	81.2	80.2	46.1	45.1	0.5	1.0
AR100WH2	100"	16:9	88.1	87.3	50.0	49.2	0.4	1.0
AR110WH2	110"	16:9	96.9	95.9	54.9	53.9	0.5	1.0
AR120WH2	120"	16:9	104.9	104.1	59.1	58.3	0.4	1.0
AR135WH2	135"	16:9	118.7	117.9	67.1	66.3	0.4	1.0
AR150WH2	150"	16:9	131.7	130.9	74.4	71.5	0.4	1.0
AR180WH2	180"	16:9	157.7	156.9	89.0	88.2	0.4	1.0
AR200WH2	200"	16:9	175.2	174.4	98.8	98.0	0.4	1.0
AR100H2	100"	16:9	88.1	87.3	50.0	49.2	0.4	1.0
AR120H2	120"	16:9	104.9	104.1	59.1	58.3	0.4	1.0
AR135H2	135"	16:9	118.7	117.9	67.1	66.3	0.4	1.0
AR92DHD3	92"	16:9	81.2	80.2	46.1	45.1	0.5	1.0
AR100DHD3	100"	16:9	88.1	87.3	50.0	49.2	0.4	1.0
AR110DHD3	110"	16:9	88.1	87.3	50.0	49.2	0.4	1.0
AR120DHD3	120"	16:9	104.9	104.1	59.1	58.3	0.4	1.0
AR135DHD3	135"	16:9	118.7	117.9	67.1	66.3	0.4	1.0
AR150DHD3	150"	16:9	131.7	130.9	74.4	71.5	0.4	1.0
AR103WH2-WIDE	103"	2.35:1	95.7	94.8	41.3	40.3	0.5	1.0
AR125WH2-WIDE	125"	2.35:1	115.9	115.0	50.0	49.0	0.5	1.0
AR138WH2-WIDE	138"	2.35:1	127.9	127.0	54.9	53.9	0.5	1.0
AR158WH2-WIDE	158"	2.35:1	146.3	145.4	62.8	61.9	0.5	1.0
AR100H2-AUHD	100"	16:9	88.1	87.2	50.0	49.0	0.5	1.0

PRODUCT WHITE PAPER

<http://www.elitescreens.com>



Model	Diag. Size	Aspect Ratio	Frame Length (A)	View Width (A1)	Overall Frame H. (B)	View Height (B1)	Frame Width (C)	Frame Depth (D)
AR120H2-AUHD	120"	16:9	104.9	103.9	59.1	58.2	0.5	1.0
Unit: mm								
AR92WH2	92"	16:9	2062	2038	1170	1146	12	25
AR100WH2	100"	16:9	2238	2218	1269	1249	10	25
AR110WH2	110"	16:9	2460	2436	1394	1370	12	25
AR120WH2	120"	16:9	2664	2644	1501	1481	10	25
AR135WH2	135"	16:9	3014	2994	1704	1684	10	25
AR150WH2	150"	16:9	3346	3326	1891	1817	10	25
AR180WH2	180"	16:9	4006	3986	2260	2240	10	25
AR200WH2	200"	16:9	4450	4430	2510	2490	10	25
AR100H2	100"	16:9	2238	2218	1269	1249	10	25
AR120H2	120"	16:9	2664	2644	1501	1481	10	25
AR135H2	135"	16:9	3014	2994	1704	1684	10	25
AR92DHD3	92"	16:9	2062	2038	1170	1146	12	25
AR100DHD3	100"	16:9	2238	2218	1269	1249	10	25
AR110DHD3	110"	16:9	2238	2218	1269	1249	10	25
AR120DHD3	120"	16:9	2664	2644	1501	1481	10	25
AR135DHD3	135"	16:9	3014	2994	1704	1684	10	25
AR150DHD3	150"	16:9	3346	3326	1891	1817	10	25
AR103WH2-WIDE	103"	2.35:1	2431	2407	1048	1024	12	25
AR125WH2-WIDE	125"	2.35:1	2945	2921	1269	1245	12	25
AR138WH2-WIDE	138"	2.35:1	3249	3225	1394	1370	12	25
AR158WH2-WIDE	158"	2.35:1	3717	3693	1595	1571	12	25
AR100H2-AUHD	100"	16:9	2238	2215	1270	1245	13	25
AR120H2-AUHD	120"	16:9	2664	2639	1501	1478	13	25

5.1.2 Aeon Spring Type Dimensions

Model	Diag. Size	Aspect Ratio	Overall Width (A)	View Width (A1)	Overall Height (B)	View Height (B1)	Frame Width (C)	Frame Thickness (D)	Support Bar Length (E)
Unit: Inches									
AR100DHD3	100"	16:9	87.6	87.2	49.5	49.0	0.2	1.3	44.7
AR110DHD3	110"	16:9	96.3	95.9	54.4	53.9	0.2	1.3	49.6
AR120DHD3	120"	16:9	105.0	104.6	59.3	58.8	0.2	1.3	54.5
AR135DHD3	135"	16:9	118.1	117.6	66.7	66.2	0.2	1.3	61.9
AR150DHD3	150"	16:9	131.2	130.7	74.0	73.5	0.2	1.3	69.2
Unit: mm									
AR100DHD3	100"	16:9	2226.2	2214	1257.2	1245	6.1	32	1135
AR110DHD3	110"	16:9	2447.2	2435	1382.2	1370	6.1	32	1260
AR120DHD3	120"	16:9	2668.2	2656	1506.2	1494	6.1	32	1384
AR135DHD3	135"	16:9	3000.2	2988	1693.2	1681	6.1	32	1571
AR150DHD3	150"	16:9	3332.2	3320	1880.2	1868	6.1	32	1758

5.2.1 Velcro Type Drawing

Diagram Shown with Optional Velvet Trim

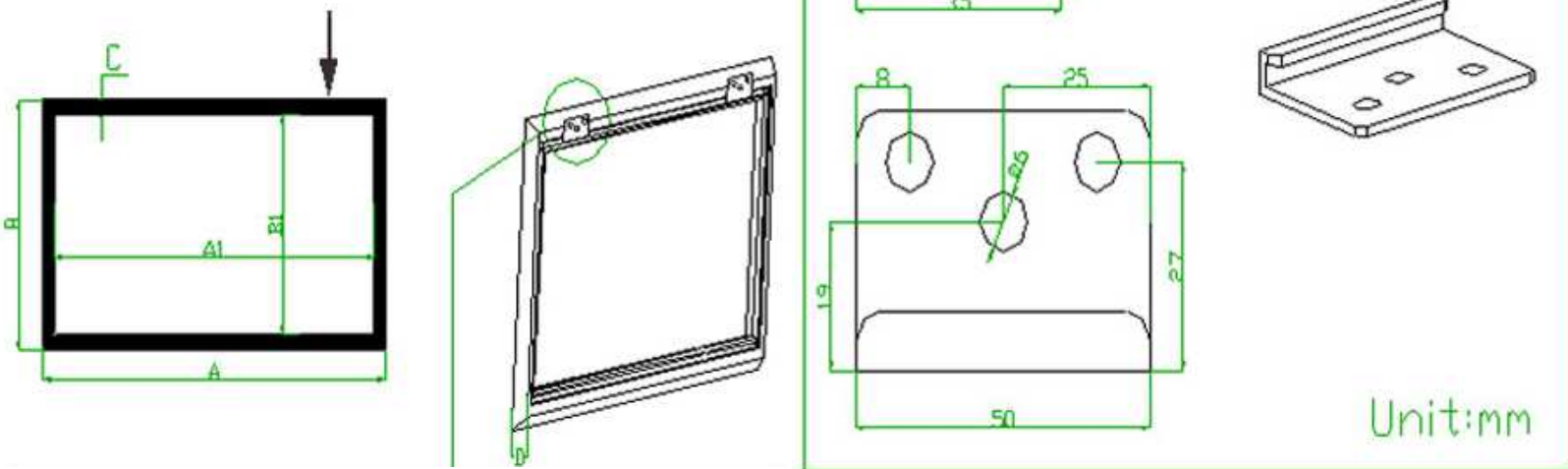

5.2.2 Spring Type Drawing

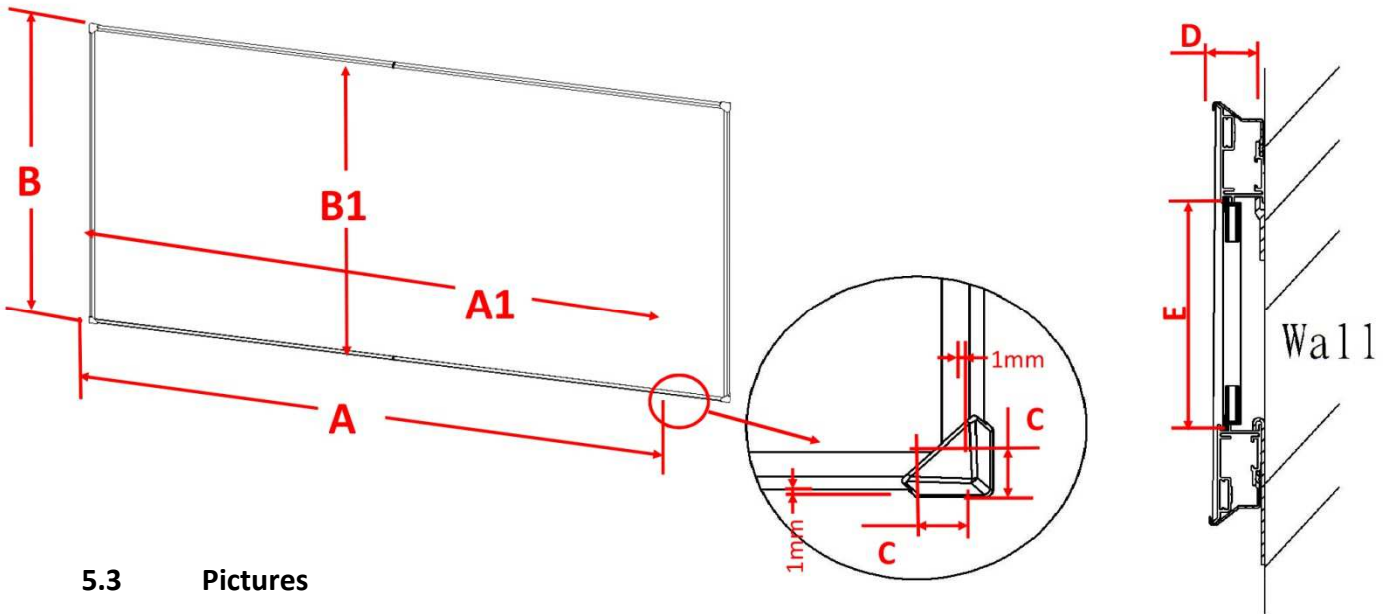

5.3 Pictures

Aeon **EDGE FREE®** Series CineGrey 3D® ALR Material – Actual Projection



PRODUCT WHITE PAPER

<http://www.elitescreens.com>



Aeon *EDGE FREE*® Series CineWhite Material – Actual Projection using Ultra Short-Throw Projector



PRODUCT WHITE PAPER

<http://www.elitescreens.com>



Thin Bezel Trim Detail – Front View



Thin Bezel Trim Detail – Side View



PRODUCT WHITE PAPER

<http://www.elitescreens.com>



Back Corner Detail – Velcro Type with AcousticPro UHD Material



Back Corner Detail – Spring Type with CineGrey 3D® Material



PRODUCT WHITE PAPER

<http://www.elitescreens.com>



Life Style with LED Backlight Kit (no projection)



Life Style





Section 6: About Elite Screens

6.1 Company Description

Elite Screens Inc. is a California based company that specializes in making quality commercial and home-theater projection screens for the retail and custom install sales channels. Our company began as an innovative venture into the projection market by manufacturing veterans from the AV/IT industry. Elite Screens quickly established itself as an entry level commercial and home theater screen manufacturer. This was accomplished by making a quality product cost effective with a focus on mass-producing screen material, sizes and aspect ratios that were most commonly preferred by AV customers in general. We focused on uniformity with what would match the mainstream demographic while including extra features that are not usually included by other manufacturers. In time, we progressed from just retail sales into the realm of custom installer/integrator manufacture as our numerous reviews and awards will attest. We stand behind our product and are so certain of customer satisfaction with the quality of our product that we offer a 2-year manufacturer's warranty which is twice the industry standard. In our continued devotion to excellence in products and service, we are committed to implementing green practices with our production. We have adopted manufacturing methods that promote conservative regulation of our energy needs. Our simple product designs combined with the expertise of our permanent staff ensures that our entire line of products are made by experienced hands devoted to the high standards of today's audio-video consumer.

###