

MICROPHONES / WIRELESS MICROPHONES / UHF

MSH-898-512

2 CHANNEL UHF WIRELESS MICROPHONE SYSTEM



PLL 32 CH
UHF 512-525 MHz

- ✓ High intelligibility sound, crisp, distortion-free speech
- ✓ 32 UHF channels
- ✓ Auto scan function.
- ✓ Channel transmission to the microphone via IR.
- ✓ Hand-held microphone and clip-on microphone



+ Info:
<https://fonestar.com/MSH-898-512>

ESPECIALLY RECOMMENDED IN:



All sectors

DESCRIPTION

UHF dual wireless microphone delivers high intelligibility sound and ensures crisp, distortion-free speech transmission, with a compact design and simple, intuitive use. It has 32 selectable channels from 512 to 525 MHz, with auto scan function and transmission of the channel to the microphone via IR. In addition, it has two unbalanced and 2 balanced outputs, which allows its connection with long cable distances avoiding induced noise in the cable and one unbalanced line mixed output. It incorporates 1 hand-held microphone and 1 clip-on microphone with belt-pack wireless transmitter and high quality dynamic capsule. Both microphone feature a unidirectional pattern which maximizes direct voice pick-up and minimizes indirect noises and sounds. Includes 19" rack 1 U assembly mount and 2 mono 6.3 mm jack cables for quick and easy installation. For fairs, seminars, classrooms, presentations, conferences, religious acts, etc.

TECHNICAL CHARACTERISTICS

FEATURES	<p>True Diversity receiver with 1 hand-held wireless microphone with unidirectional electret condenser capsule and 1 clip-on microphone with unidirectional electret condenser capsule and wireless belt-pack transmitter.</p> <p>Auto scan function.</p> <p>IR channel to microphone transmission.</p> <p>Detachable antennas.</p> <p>With multiple receivers, maximum 4 - 5 microphones at the same time. For more microphones use other frequency bands.</p>
FREQUENCIES	512-525 MHz 32 channels
POWER	10 mW maximum
RESPONSE	40-18,000 Hz
S/N RATIO	> 105 dB
INPUTS	2 antennas, TNC female, 50 Ohm. With 8 V DC output for power supply of antenna amplifiers
OUTPUTS	<p>Audio:</p> <p>2 balanced, XLR, 0 ~ 600 mV, 600 Ohm</p> <p>2 unbalanced, 6.3 mm jack, 0 ~ 300 mV, 1 KOhm</p> <p>1 unbalanced line mixed signal, 6.3 mm jack, 0 ~ 300 mV, 1 KOhm</p>
MICROPHONES	<p>1 hand-held wireless microphone with unidirectional electret condenser capsule</p> <p>1 lavalier microphone with unidirectional electret condenser capsule and wireless belt-pack transmitter</p>



+ Info:

<https://fonestar.com/MSH-898-512>

DIMENSIONS	Receiver: 420 x 45 x 207 mm depth
WEIGHT	2.3 kg
POWER SUPPLY	Receiver: 12.8 V DC, 450 mA, with adapter included Transmitter microphone: 2 LR6-AA batteries. Accepts rechargeable batteries.
ACCESSORIES	Mounts for assembling in 1 U 19" rack 2 x 6.3 mm mono jack cables Rechargeable batteries
OPTIONAL	MSC-2 and MSC-12: wireless microphone recharge docking stations



+ Info:

<https://fonestar.com/MSH-898-512>

MSHR-46D

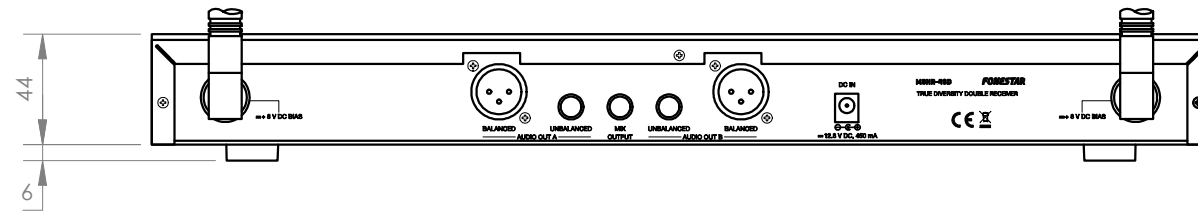
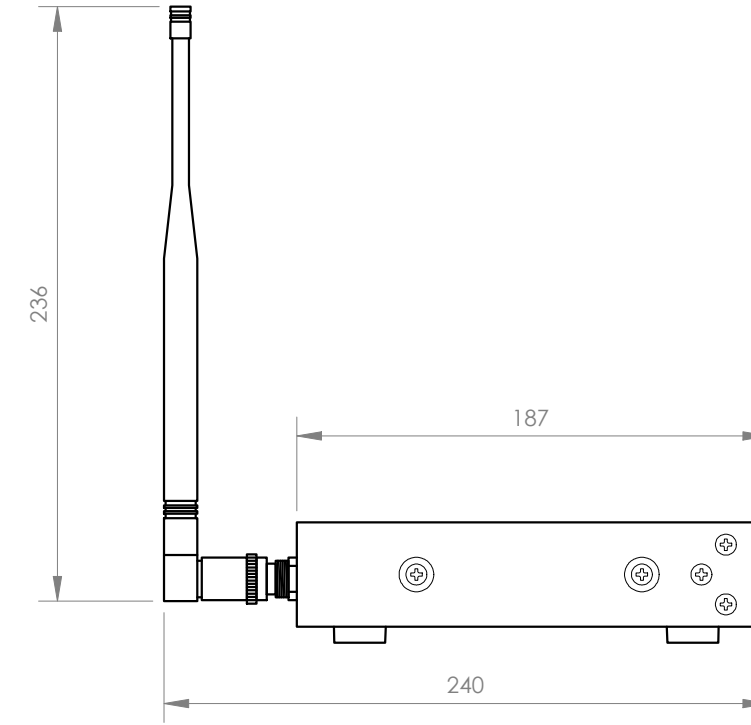
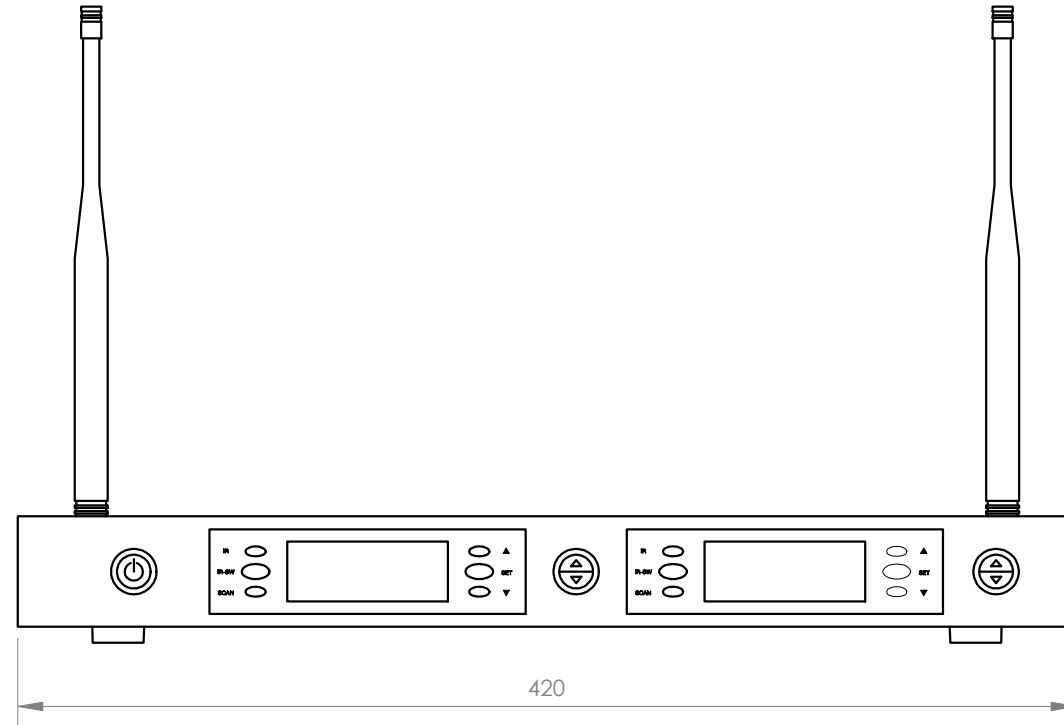

MSHT-40

MSHT-45P

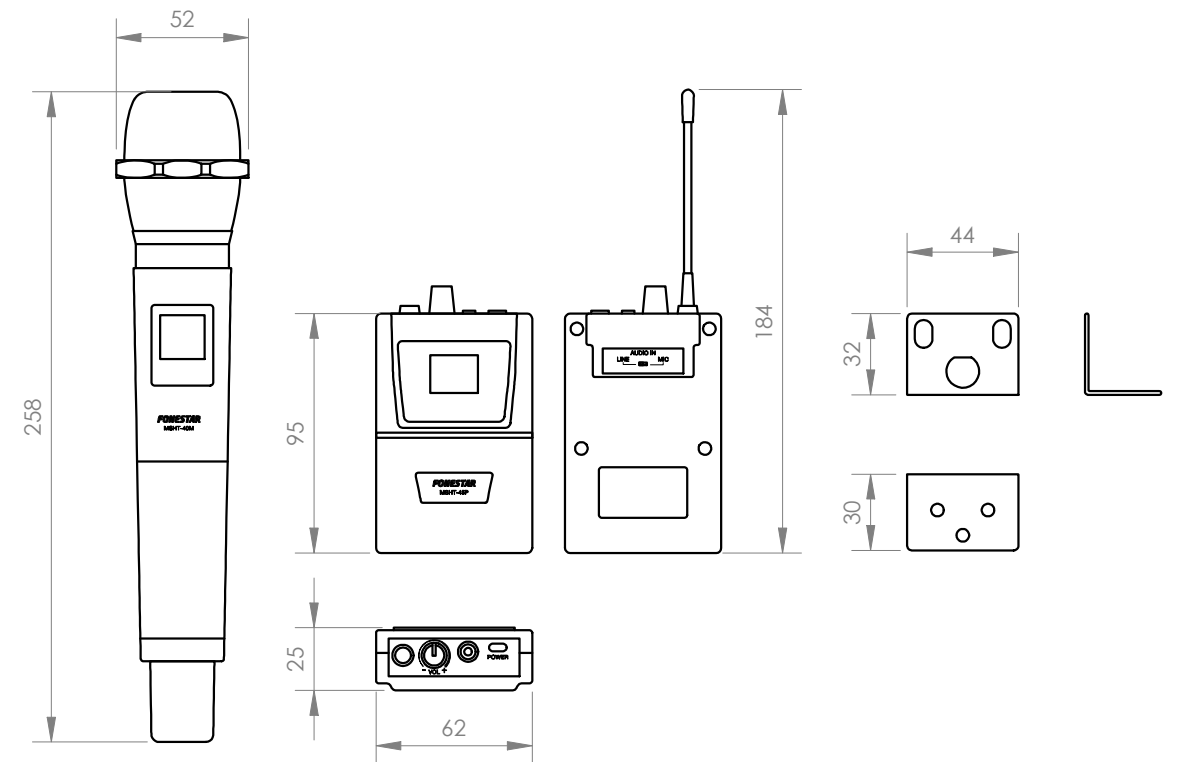

FONESTAR	Model	Description	Units	Scale
	MSH-898	DOUBLE UHF WIRELESS MICROPHONE	mm	1:3