



The **CINE PRO** is a large dimension electrical screen available from 8 mt. up to 12 mt. of width.

Cine Pro is the best choice for cinemas, theatres or auditoriums. It assures the possibility to join the need to have projections and the alternative to play a performance on a stage.

The Cine Pro structure is equipped with an aluminium tube which is, at the same time, rolling pipe and bottom bar.

The capstan electric motor unit which is located in the middle of the structure, transmits, by the steel cables, the rotation of the winding pipe determining the rolling up or the descent of the cloth in a quiet and safe way.

The Screen Int. R&D department has developed a new and unique **SAFETY SYSTEM** that prevents eventual rolling down of the aluminium tube, in case of accidental failure of the motor or of the steel cables or of the cloth.

Available in bespoke sizes.

Screen housing available also in black colour (optional)

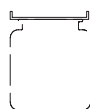
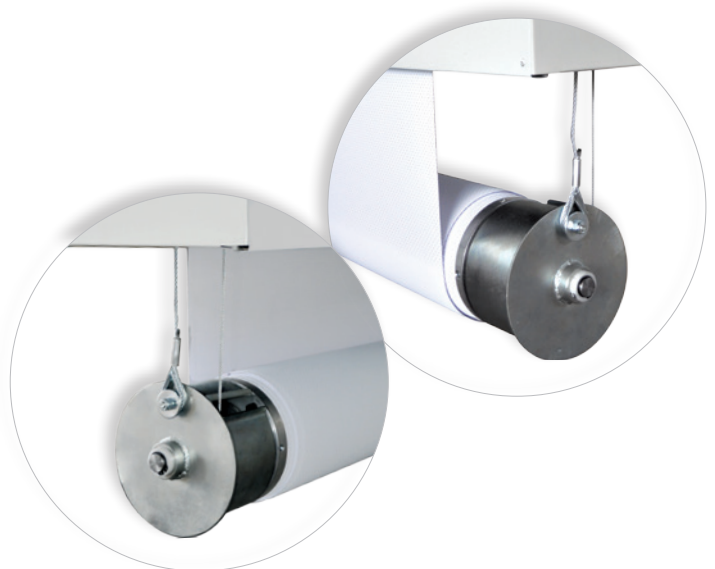

Ceiling mounting brackets



n.1 On/off switcher

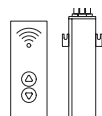

Kit RF Remote control with external receiver



Interface switch 12 volt



Low voltage contact interface

INCLUDED

OPTIONAL pag 62-63

CINE PRO CLOSED

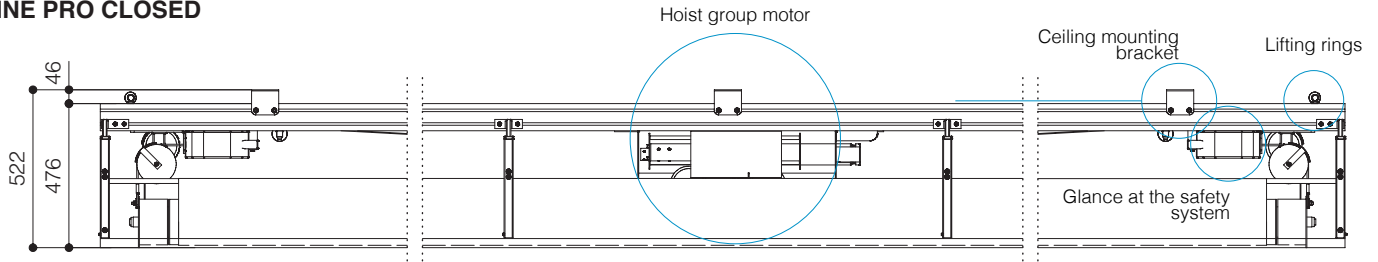

CINE PRO OPEN

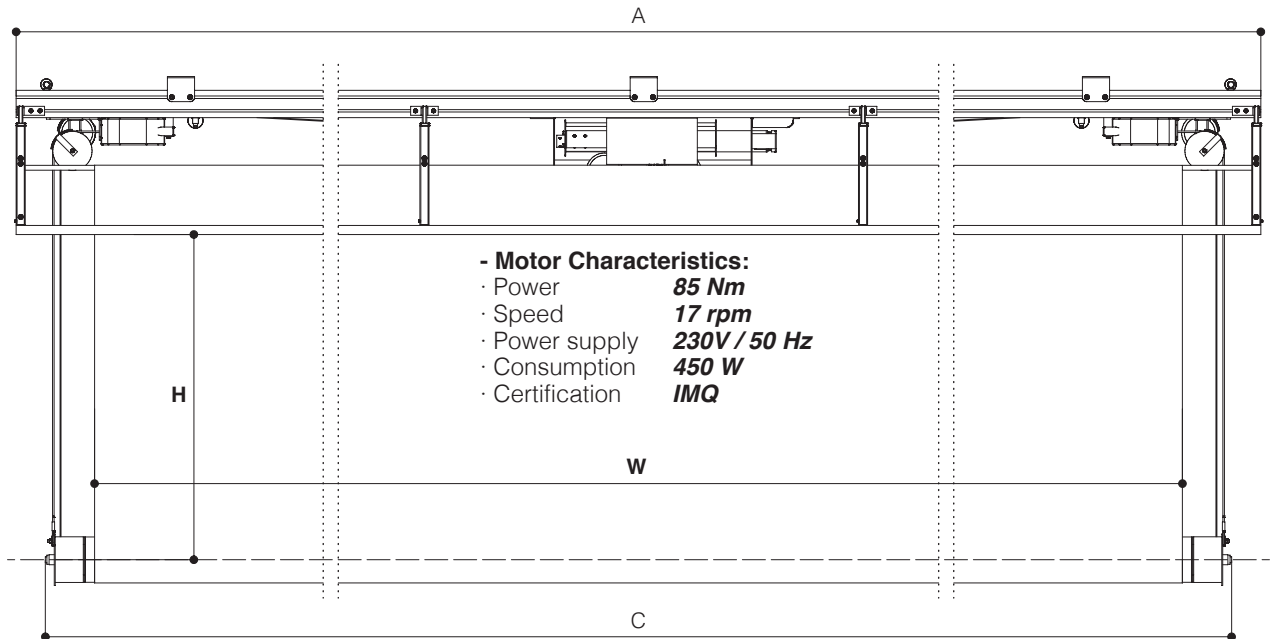

CEILING MOUNTING BRACKETS

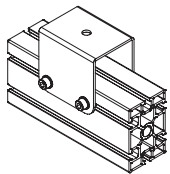

SIDE VIEW

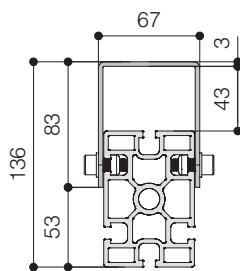

FRONT VIEW

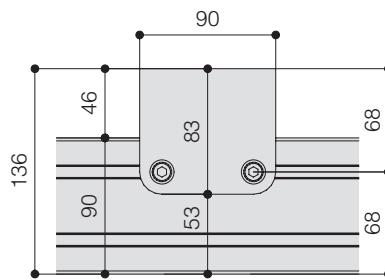

HOUSING SIDE VIEW

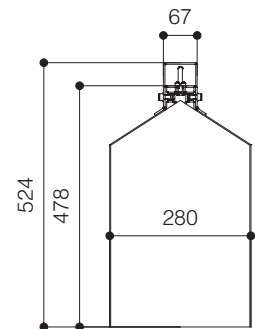

NOTE: The left and the right anchoring points have to be fixed at the same distance from each end side of the cabinet. The fixing distance has to be maximum 50 cm from left and right end sides of the cabinet.

The measures in the drawings are expressed in millimetres.

DIMENSIONS measures in cm

Viewing area (WxH)	Overall dimensions A - C	Approx. net weight (Kg)	Approx. gross weight (Kg)	Rolling down/up time (sec)
800 x 450	848 - 840	227	491	59
900 x 500	948 - 940	249	554	65
1000 x 550	1048 - 1040	270	614	71
1100 x 600	1148 - 1140	292	680	78
1200 x 650	1248 - 1240	314	746	85

PROJECTION CLOTHS

Front projection surfaces	Gain	Rear projection surfaces	Gain
White*	1.2	Rear Plus*	1.1
Microholes*	1.0	Front Rear*	0.9

*Weldings on the projection surface

Warranty: 5 years on the motor - 24 months on the other components

